



STRATEGIES FOR NORTHERN DEVELOPMENT (SND) – KENYA

- REQUEST FOR TENDER FOR CONSTRUCTION OF CENTRE OF EXCELLENCE FOR NAKURON BMU

HARRY THUKU LANE, OFF MARSABIT GENERAL HOSPITAL ROAD,
BEHIND CATHOLIC CHURCH-MARSABIT

OFF WILDLIFE ROAD, ADJACENT TO KENYA NATIONAL LIBRARY.

Tel: [+254] 741845578

E-mail: info@sndafrica.org

Website: www.sndafrica.org

REF: [SND -WFP/ LTP- COE NAKURON BMU/2026- 01](#)

Closing Date: 27th May 2026

REQUEST FOR QUOTATION

RE: CONSTRUCTION OF CENTRE OF EXCELLENCE FOR LOIYANGALANI BMU

The Strategies for Northern Development (SND), is a local non-governmental organization working with nomadic pastoralist communities in Northern Kenya and Southern Ethiopia. SND was registered in Kenya with the NGO Coordination Board as a fully-fledged NGO on 6th December 2007.

SND is driven by a vision to see a society where all pastoralist communities are resilient and live a dignified life and a mission to empower and transform pastoralist communities to be self-resilient in life. Key thematic areas of focus are;

- i. Peace, Conflict Resolution and Governance
- ii. Humanitarian Assistance and Emergency Response
- iii. Protection, Gender Equality and Inclusion
- iv. Climate Justice and Resilience
- v. Livelihood and Enterprise Development
- vi. Water, Sanitation, and Hygiene (WASH).
- vii. Institutional Effectiveness

SND in collaboration with the County Government of Marsabit through funding from WFP intend to **support Construction of Nakuron BMU in Loiyangalani Ward, Laisamis Sub County, Marsabit County.**

For this purpose, we invite bidders to submit quotations for the execution and completion of the above assignment, as outlined in the quotation document.

NB: Prices quoted should be **exclusive of VAT**. The successful vendor(s) will be issued with a VAT Exemption Certificate for this assignment.

DESCRIPTION OF WORK/SERVICE

CONSTRUCTION OF CENTRE OF EXCELLENCE FOR NAKURON BMU

Item	Description	Unit	Qty	Rate	Amount
	Allow for mobilization and demobilisation of machinery, equipment, personel, provision of security, personal protective equipment and setting up of contractor's base camp	sum	1		

	Allow for transportation of construction materials	sum	1		
	Allow for insurance of works, machinery/equipment, staff and materials	sum	1		
	Provide, fix and maintain project sign board per drawing (including any payments to local authorities) through to end of defects liability period of contract	sum	1		
	Provisional Sum for fees requested by various authorities and agencies including NEMA, WARMA & County Governments	sum	1		
	Allow a fixed sum of 150000 KES for county supervision	sum	1	150,000.00	150,000.00
	Allow a 15% adjustment to the county supervision sum	%	15		
	Total				
Item	Description	Unit	Qty	Rate	Amount
	<u>Foundation</u>				
	<u>Excavation</u> <i>(Rates to include disposal of excavation spoil, shoring, dewatering, levelling)</i>				
	Excavation over site to depths N.e 0.15	m ²	32		
	Excavation for strip to depths N.e 1 m	m ³	15		
-	<u>Reinforced concrete Class 20 in:</u> <i>Rates to include casting in situ & placement</i>	-	-	-	
	200mm thick strip Foundation (1:2:4)	m ³	3		
	BRC A142 with 150mm laps	m ²	15		
	<u>Foundation walling</u>				
	200mm Thick masonry wall to the foundation with hoop iron at every alternative course c/s ratio 1:3 and 16mm Joints	m ²	20		
	<u>Hardcore and murrum</u>				
	300mm Handpacked Hardcore filling in making levels not exceeding layers of 150mm maximum thickness	m ³	10		
	DPM 1000 gauge	m ²	32		
	BRC mesh A 142	m ²	32		
	200 mm thick C20 concrete slab	m ³	5		

	Super structure				
	Masonry Walling <i>(Dressed masonry walling in cement and sand (1:3) mortar reinforced with and including 25 x 3mm thick hoop iron in every alternate course.)</i>				
	200mm Masonry walling	m ²	12		
	Gauge 28 IT5 Prepainted Box profile for walling	m ²	53		
	Foundation Subcolumns				
	Form Work <i>(Provide and fix shuttering including propping, strutting and striking all as specified)</i>				
	sawn form work smooth finish to:				
	300mm x 300mm Sub columns	m ²	22		
	Reinforcement <i>(Rates to include cutting, bending, laps allowance and placing on site)</i>				
	D12 (0.89kg/m)	kgs	214		
	D8 (0.395kg/m)	kgs	40		
	M16 x 150mm threaded foundation Bolts, nuts, and washers	nr	48		
	250mm x 250mm x 10mm Foundation base plates	nr	12		
	Concrete <i>(Vibrated reinforced concrete class 20 (1:2:4) with 20mm maximum aggregate as described in)</i>				
	300mm x 300mm sub columns	m ³	3		
	Square Hollow Sections <i>Supply, fabricate, install with jointed bolts including all necessary cutting, drilling of holes, hoisting, fixing in position, and making connections with high-strength bolts, nuts, and washers as per approved detailed drawings and engineer's instructions. This item also includes the application of one coat of approved steel primer and three coats of super gloss paint on new work, complete as specified"</i>				
	50mm x 50mm x 3mm SHS 2.5 meter high prepainted SHS stanchions welded on baseplates 4.56(kg/m)	kgs	137		
	50mm x 50mm x 2mm SHS for (joists, sills, wallplates, siderails, topplates, and headers) (3.07kg/mtr)	kgs	305		
	Roofing				

	Allow for supply fabrication and installation of roofing trusses with 50mm x 25mm x 3mm RHS Rafters ,50mm x 25mm x 3mm RHS struts and webs as detailed (Rates to include bolting and joinery works using 8mm plates, bolts, nuts and washers)	nr	4		
	50mm x 25mm x 3mm prepainted Purlins at 1300mm C-C spacing (3.39kg/mtr)	kgs	184		
	Subtotal 1				=====
	Cladding				
	Gauge 28 IT5 box profile	m ²	42		
	Gauge 28 ridge cap	mtrs	9		
	200mm x 25mm prepainted Fascia board	mtrs	30		
	150mm PVC gutters <i>Heavy duty UPVC rainwater gutters & down pipes and fittings : solvent welded and jointing in approved adhesive built into concrete or fixed with approved holder brackets: to approval(provisional)</i>	mtrs	18		
	Finishes				
	Floor Finishes cement sand screed as described in:				
	30mm thick screed with a steel finish finished smooth with red oxide	m ²	32		
	Wall Finishes				
	25mm thick plaster trowelled to smooth finish to external and internal walls	m ²	24		
	Paint works <i>Prepare and apply three coats all weather emulsion paint to:</i>				
	Plastered walls	m ²	24		
	Doors & Windows				
	Windows <i>Supply and Fix the following purpose made steel casement windows manufactured from heavy duty standad sections primed with three coats of super gloss paint and fixing to SHS head and side jambs complete with closing mechanism and other fittings.</i>				
	Window size 1600 x 1200 mm windows with 4mm glazing and buglar proof	nr	4		

	<p>Doors Standard section purpose made heavy duty steel casement doors in modular panes complete with frame, sub-frame, mullions, transomes, glazing bars, burglar proofing bars horizontally and verticaly in all openable panes, all necessary pegs, polished brass handles and stays, pin type heavy duty hinges, mosquito proofed hooded permanent vent, fixing lugs cast on, three coats od super gloss paint before fixing in position and pointing with approved mastic sealant all round frame</p>				
	<p>Builders works related to services installations Provide for all the necessary builders works in connection with all the electrical services installation works (cabling, wiring, lighting, sockets, Trunking, pattresses, Distribution boards and fittings)</p>	Sum	1		
	<p>Tank and Fittings (Rates to include supply, placement and installation accessories)</p>				
	<p>10m3 plastic tank (Short tank) Tank should include a DN 15mm drawoff tap, OD 50mm Overflow provision. walls should be corrugated, One-piece moulding with no joints,leak-proof and should be able to withstand long exposure to sunlight. preferably Kentank/Rototank</p>	nr	1		
	<p>Construction of a 400mm high (agl) x 3000mm wide Masonry base with 200mm thick BRC reinforced C20 concrete 1:2:4 slab on 300mm thick hand compacted hardcore, with walls plastered and top slab finished with a 25mm cement sand screed motor, trowelled smooth</p>	sum	1		
	Subtotal 2				=====
	Collection page				-
	Sub Total 1 Brought Forward				=====
					-
	Sub Total 2 Brought Forward				=====
					-
	Grand Total				=====

Cleaning Shade

Item No	Description	U.O.M	Qty	Rate	Amount
	<u>Foundation</u>				
	<p><u>Excavation</u> <i>(Rates to include disposal of excavation spoil, shoring, dewatering, levelling)</i></p>				
	Excavation over site to depths N.e 0.15	m ²	31		

	Excavation for strip to depths N.e 1 m	m ³	17		
-	Reinforced concrete Class 20 in: <i>Rates to include casting in situ & placement</i>	-	-		
	200mm thick strip Foundation (1:2:4)	m ³	4		
	BRC A142 with 150mm laps	m ²	17		
	Foundation walling				
	200mm Thick masonry wall to the foundation with hoop iron at every alternative course c/s ratio 1:3 and 16mm Joints	m ²	28		
	Hardcore and murram				
	300mm Handpacked Hardcore filling in making levels not exceeding layers of 150mm maximum thickness	m ³	10		
	DPM 1000 gauge	m ²	31		
	BRC mesh A 142	m ²	31		
	150 mm thick concrete slab	m ³	5		
	Cleaning stand				
	Masonry Walling <i>(Dressed masonry walling in cement and sand (1:3) mortar reinforced with and including 25 x 3mm thick hoop iron in every alternate course.)</i>				
	150mm Masonry walling	m ²	23		
	Formwork				
	Fair finish Formwork to soffits of suspended slabs/beams, propped up to 1m high	m ²	13		
	Fair finish formwork to vertical sides of slabs	m ²	9		
	Reinforcement <i>rates to include stools, bending, overlaps & fixing</i>				
	D10 rebars unit weight 0.62kg/m	kgs	89		
	Reinforced concrete Class 20 in: Rates to include casting in situ & placement				
	Vibrated C15/20 Concrete (1:2:4) to work tops	m ³	2		
	Finishes				

	Wall finishes 15mm plaster: Cement and sand mortar (1:2) as described to:				
	Vertical walls with 5mm cement grout finish	m ²	46		
	Floor Finishes cement sand screed as described in:				
	30mm thick screed with a steel finish finished smooth	m ²	9		
	Tiling				
	Supply and fix 300mm x 300mm x 4mm ceramic tiles aligned and finished with recommended grout and metal strips on working tops	m ²	9		
	Plumbing works & Fittings				
	Supply and fix Single bowl stainless steel kitchen sink c/w all plumbing, drainage and installation accessories	nr	6		
	1" PPR pipes PN 20	m	12		
	1" PPR Elbows	nr	6		
	1" PPR tees	nr	8		
	1" PPR Female adaptors	nr	8		
	1" PPR sockets	nr	6		
	1" PPR Endcaps	nr	2		
	1" x 150mm Borell nipple	nr	8		
	1" x 1/2" GI reducer sockets	nr	8		
	Sub total 1				
	1/2" Taps pegler	nr	6		
	1" male threaded PPR Adaptors	nr	2		
	1" GI union	nr	1		
	1" GI Hex nipples	nr	2		
	1" gate valve (pegler)	nr	1		
	Canopy				
	Square Hollow sections <i>(Rates to include cutting, welding, Jointing, bolting, laps allowance and placing on site)</i>				

	Prepainted 50mm x 50mm x 2mm SHS framing for super structure embedded 0.5m BGL (struts and corner posts) (3.08kg/mtr)	kgs	56		
	Prepainted 50mm x 50mm x 2mm RHS framing for super structure (top plate)(3.08kg/mtr)	kgs	20		
	Roofing Works				
	Steel works (Rates to include for delivery, cuttings, welding, Bolting, fastenning with hoop iron and joinery lap allowance and placing on site)				
	Allow for supply fabrication and installation of prepainted 50mm x 25mm x 2mm SHS roofing trusses at 3300mm spacing C-C as detailed	nr	3		
	Supply and installation of prepainted 50mm x 25mm x 2mm purlins @ 1060mm spacing C-C	kgs	110		
	200mm x 25mm prepainted Fascia board	mtrs	25		
	Cladding (Rates to include overlaps, roofing accessories, ridgecaps, valleys and fixing in place)				
	Gauge 28 box profile sheets(blue painted)	m ²	35		
	Gauge 28 Ridge cap	m	8		
	150mm PVC gutters Heavy duty UPVC rainwater gutters & down pipes and fittings and connection to tank : solvent welded and jointing or fixed with approved holder brackets: to approval(provisional)	mtrs	20		
	Tank and Fittings (Rates to include supply, placement and installation accessories)				
	5m3 plastic tank (Short tank) Tank should include a DN 15mm drawoff tap, OD 50mm Overflow provision. walls should be corrugated, One-piece moulding with no joints,leak-proof and should be able to withstand long exposure to sunlight. preferably Kentank/Rototank	nr	1		
	Construction of a 400mm high (agl) x 2000mm wide Masonry base with 200mm thick BRC reinforced C20 concrete 1:2:4 slab on 300mm thick hand compacted hardcore, with walls plastered and top slab finished with a 25mm cement sand screed motor, trowelled smooth	sum	1		
	Finishes				

	Floor Finishes cement sand screed as described in:				
	30mm thick screed with a steel finish finished smooth with red oxide	m ²	32		
	Allow for waste water draunage works and excavation of a 2 x 1.5x 3meter soakpit filled with hardcore	sum	1		
	Subtotal 2				
	Collection page				
	Sub Total 1 Brought Forward				
	Sub Total 2 Brought Forward				
	Grand Total				
6 meter Elevated tower					
Item No	Description	U.O.M	Qty	Rate	Amount
	Earthworks				
	Excavations for foundations <i>Rates to include cuttings, trimming of excavated surfaces, shoring, dewatering and disposal of excavated spoil</i>				
	Excavation for 4 No column bases maximum depth n.e 1.5 meter	m ³	4		
	Rock excavation maximum depth n.e 1 meters	m ³	3		
	Filling <i>Rates to include importation, selection and compaction of appropriate backfilling materials</i>				
	Selected fill to Excavation extras	m ³	4		
	Foundation subcolumns				
	Reinforcement <i>(Rates to include cutting, bending, laps allowance and placing on site)</i>				
	D12 (0.89kg/m)	kgs	65		
	D8 (0.395kg/m)	kgs	15		
	M16 x 150mm threaded foundation Bolts, nuts, and washers	nr	16		
	250mm x 250mm x 10mm Foundation base plates	nr	4		

	Concrete <i>(Vibrated reinforced concrete class 20 (1:2:4) with 20mm maximum aggregate as described in)</i>				
	4 No. 300mm x 300mm sub columns	m ³	2		
	Form Work <i>(Provide and fix shuttering including propping, strutting and striking all as specified)</i>				
	sawn form work smooth finish to:				
	300mm x 300mm Sub columns	m ²	8		
	Super structure				
	Square Hollow Sections <i>Supply, fabricate, install with 6mm Bolting plates, jointed bolts including all necessary cutting, drilling of holes, hoisting, fixing in position, and making connections with high-strength bolts, nuts, and washers as per approved detailed drawings and engineer's instructions. This item also includes the application of one coat of approved steel primer and three coats of super gloss paint on new work, complete as specified"</i>				
	6 meter 75x75x4mm SHS Stanchions welded on base plates (9.04kg/mtr)	kgs	220		
	75x50x4mm RHS Primary beam (7.6kg/mtr) for top and bottom platform	kgs	190		
	75x50x4mm RHS Secondary beam (7.6kg/mtr) for top and bottom platform	kgs	502		
	4mm Checkered plate for top and bottom platform	m ²	18		
	50x2mm angle lines for diagonal bracings (2.3kg/mtr)	kgs	243		
	40mm x 40mm x 2mm SHS sections for walkway guard rails (top and bottom platform) and access Ladder fabrication(2.45kg/mtr)	kgs	253		
	Tanks and Plumbing Accessories				
	10m ³ plastic tank (regular Dia 2.21m x H 2.84m) Tank should include a DN 50mm offtake, OD 50mm Washout OD 50mm Overflow provision. walls should be corrugated, One-piece moulding with no joints,leak-proof and should be able to withstand long exposure to sunlight. preferably Kentank/Rototank	nr	1		

	5m ³ plastic tank (regular Dia 1.8m x H 2.11m) Tank should include a DN 50mm offtake, OD 50mm Washout OD 50mm Overflow provision. walls should be corrugated, One-piece moulding with no joints,leak-proof and should be able to withstand long exposure to sunlight. preferably Kentank/Rototank	nr	1		
	Allow for plumbing and tank interconnection works to the source and cleaning area	sum	1		
	Total				
Item No	Description	U.O.M	Qty	Rate	
	<u>Foundation</u>				
	<u>Excavation</u> <i>(Rates to include disposal of excavation spoil, shoring, dewatering, levelling)</i>				
	Excavation over site to depths N.e 0.15	m ²	91		
	Excavation for strip to depths N.e 1 m	m ³	24		
-	Reinforced concrete Class 20 in: <i>Rates to include casting in situ & placement</i>	-	-	-	
	200mm thick strip Foundation (1:2:4)	m ³	6		
	BRC A142 with 150mm laps	m ²	30		
	<u>Foundation walling</u>				
	200mm Thick masonry wall to the foundation with hoop iron at every alternative course c/s ratio 1:3 and 16mm Joints	m ²	40		
	<u>Hardcore and murrum</u>				
	300mm Handpacked Hardcore filling in making levels not exceeding layers of 150mm maximum thicknes	m ³	28		
	DPM 1000 gauge	m ²	91		
	BRC mesh A 142	m ²	91		
	150 mm thick concrete slab	m ³	14		
	<u>Super Structure</u>				
	Masonry Walling <i>(Dressed masonry walling in cement and sand (1:3) mortar reinforced with and including 25 x 3mm thick hoop iron in every alternate course.)</i>				
	200mm Masonry walling	m ²	27		
	Gauge 28 IT5 Prepainted Box profile for walling	m ²	148		

	Square Hollow sections <i>(Rates to include cutting, welding, Jointing, bolting,laps allowance and placing on site)</i>				
	Prepainted 50mm x 50mm x 3mm SHS framing for super structure (struts and corner posts)	kgs	435		
	Prepainted 50mm x 25mm x 3mm RHS framing for super structure (joists, sills, topplates and headers)	kgs	652		
	Roofing Works				
	Steel works <i>(Rates to include for delivery, cuttings, welding, Bolting, fastenning with hoop iron and joinery lap allowance and placing on site)</i>				
	Allow for supply fabrication and installation of prepainted 50mm x 25mm x 2mm SHS roofing trusses at 3200mm spacing C-C as detailed	nr	6		
	Supply and installation of prepainted 50mm x 25mm x 2mm purlins @ 1250mm spacing C-C	kgs	366		
	30mm x 30mm x 2mm roof parapet Frame work as specified	kgs	228		
	Cladding <i>(Rates to include overlaps, roofing accessories, ridgecaps, valleys and fixing in place)</i>				
	Gauge 28 box profile sheets(blue painted)	m ²	101		
	Gauge 28 box profile for parapet walling	m ²	30		
	150mm PVC gutters <i>Heavy duty UPVC rainwater gutters & down pipes and fittings : solvent welded and jointing or fixed with approved holder brackets: to approval(provisional)</i>	mtrs	20		
	Finishes				
	Wall finishes <i>15mm plaster: Cement and sand mortar (1:2) as described to:</i>				
	Interior & Exterior wall surfaces	m ²	53		
	Sub total 1				
	Floor Finishes cement sand screed as described in:				
	30mm thick screed with a steel finish finished smooth with red oxide	m ²	82		
	Paint works				
	3 coats of Vinyl emulsion premium all-weather paint on plastered surfaces	m ²	53		

	Doors & Windows				
	Windows <i>Supply and Fix the following purpose made steel casement windows manufactured from heavy duty standad sections primed with three coats of super gloss paint and fixing to masonry or concrete head and jamb complete with closing mechanism and other fittings.</i>				
	Window size 1800 x 1200 mm windows with glazing buglar proof	nr	5		
	Window size 1500 x 1200 mm windows with 4mm glazing and buglar proof	nr	5		
	Doors <i>Standard section purpose made heavy duty steel casement doors in modular panes complete with frame, sub-frame, mullions, transomes, glazing bars,buglar proofing bars horizontally and verticaly in all openable panes, all necessary pegs, polished brass handles and stays, pin type heavy duty hinges, mosquito proofed hooded permanent vent, fixing lugs cast on, three coats od super gloss paint before fixing in position and pointing with approved mastic sealant all round frame</i>				
	Double leaf Door size 1200 x 2400mm with 1.2mm thick panel face and 4mm glazing	nr	5		
	Builders works related to services installations				
	Provide for all the necessary builders works in connection with all the electrical services installation works (cabling, wiring, Trunking, pattresses, Distribution boards and fittings)	Sum	1		
	Subtotal 2				
	Collection page				
	Sub Total 1 Brought Forward				
	Sub Total 2 Brought Forward				
	Grand Total				
Item	Description	Unit	Qty	Rate	Amount
	Earthworks				
	Excavations for Cuttings <i>(Rates to include cutting, shoring, trimming, dewatering and disposal of excavated spoils approved materials shall be used for backfill and unsuitable materials disposed to tip as specified)</i>				
	Top soil, maximum depths n.e 0.25 meters	m ³	50		
	materials other than topsoil, rock, or artificial hard material				

	Depth: 0.5-1 meter	m ³	10		
	Rock material Depth: 0.5-1 meter	m ³	10		
	Gabion installation <i>Rates to include supply, assembly, placing, filling. Gabions must be filled carefully to maintain alignment, avoid bulging, and ensure a dense, stable mass. and securing the cages</i>				
	Provide, assemble, place 2m x 1m x 1m Double-twisted hexagonal mesh (woven) zinc-coated galvanized gabion boxes of mesh size 100 x 80mm and wire diameter 3mm including binding, aligning and stretching, as specified	nr	50		
	Provide, assemble and place Double-twisted hexagonal mesh of 60mm x 80mm Reno mattresses, size 2m(L) x 1m(W) x 0.3m(H), Class A galvanized with wire diameter 4mm placed on a prepared surface along the Lake shore	m ²	200		
	provide and place rock fill to Gabions and Gabion mattresses	m ³	200		
	Supply and lay non-woven needle-punched geotextile filter fabric (minimum weight 200-270g/m ² to the rear and underside of the gabion structure with minimum overlaps of 500mm at joints, inclusive of all waste, cutting, and securing in position as instructed	m ²	200		
	1 1/2" GI Class B anchored along the Gabion wall length at 3 meter spacing for boat mooring	m	50		
	Filling <i>Rates to include importation, selection and compaction of appropriate backfilling materials</i>				
	Selected fill to Gabion wall Foundations and wall surfaces	m ³	30		
	imported fill for the formation of a 25-meter-long x 10meter wide x 1 meter high pier, compacted in layers	m ³	250		
	Allow provisional sum for trench dewatering during excavations	Sum	1		
	Total				
BOQ for Construction of a twin Latrine					
S/No	Description	U.O.M	Qty	Rate	Amount
	Foundation works <i>(Quantities provided are provisional)</i>				
	Excavation <i>Rates to include spoil Disposal, maintaining and supporting sides and keeping free from water, mud and fallen materials by bailing, pumping or otherwise</i>				
	Excavation to depth n.e 1 Mtrs	m ³	4		

	Concrete works <i>Vibrated reinforced concrete class 20 (1:2:4) with 20mm maximum aggregate as described in:</i>				
	Strip Foundation	m ³	1		
	Reinforcement <i>(Rates to include cutting, bending, laps allowance and placing on site)</i>				
	D8 reinforcement bars (weighing 0.395kg/m) (measured net-no allowance made for laps)	Kgs	15		
	Masonry Walling <i>(Foundation quarry stone walling in cement and sand (1:2) mortar reinforced with and including 25 x 3mm thick hoop iron in every alternate course.)</i>				
	200mm for strip foundation	m ²	9		
	Floor Slab				
	Water proofing				
	Single layer of 100 gauge polythene sheeting laid on slab soffits with 150 mm side laps to receive concrete	m ²	3		
	Reinforcement <i>(Rates to include cutting, bending, laps allowance and placing on site)</i>				
	D10 reinforcement bars (weighing 0.62kg/m) (measured net-no allowance made for laps)	kgs	46		
	Form Work <i>(Provide and fix shuttering including propping, strutting and striking all as specified)</i>				
	sawn form work fair finish to:				
	Formwork to edges of floor slab girth not exceeding 200mm	m	7		
	Soffits	m ²	3		
	Concrete <i>(Vibrated reinforced concrete class 20 (1:2:4) with 20mm maximum aggregate as described in)</i>				
	200mm floor slab	m ³	0.6		
	Super Structure				

Masonry Walling <i>(Dressed masonry walling in cement and sand (1:2) mortar reinforced with and including 25 x 3mm thick hoop iron in every alternate course.)</i>				
200mm Masonry walling	m ²	9.5		
75mm x 50mm Sawn cypress wall plate	m	10		
75mm x 50mm sawn cypress for studs, trimmers, bracing and top plates	m	100		
Gauge 28 profile sheets(blue painted)	m ²	36		
Roofing Works				
Capentry & Joinery <i>(Rates to include for delivery, cuttings, fastenning with hoop iron and joinery)</i>				
75mm x 50mm Sawn cypress for Rafters and purlins	mtrs	26		
Prepainted 200mm x 25mm Fascia board	mtrs	11		
Cladding				
Gauge 28 profile sheets(blue painted)	m ²	8		
Subtotal 1				
Finishes				
Wall finishes 15mm plaster: Cement and sand mortar (1:2) as described to:				
Interior wall surfaces	m ²	6		
Floor Finishes cement sand screed as described in:				
32mm thick screed	m ²	2.5		
Doors & Windows				
Windows <i>Supply and Fix the following purpose made steel Loured windows manufactured from heavy duty standadsections primedwith one coat of red oxide primer and fixing to masonry or concrete head and jambcomplete with closing mechanism and other fittings.</i>				
Window size 600 x 600 mm glass windows with glazing	Pcs	2		
Doors				
Supply and fixing of 50mm thick solid Cored ordinary flush door size 900mm x 2100mm with lipping	No	2		
3 Lever Mortice Lock	No	2		
Pit Latrine (0.9mtrs x 1.5mtrs x 5				

	Excavation for cuttings				
	Excavation for top soil depth n.e 0.25	m ³	0.4		
	Depth between 0.25 - 0.5	m ³	0.4		
	Depth between 0.5 - 1	m ³	0.8		
	Depth between 1 - 2	m ³	1.5		
	Depth between 2 - 5	m ³	5		
	Allow a provisional sum for rock excavation	m ³	7		
	Subtotal 2				
	Collection page				
	Sub Total 1 Brought Forward				
	Sub Total 2 Brought Forward				
	Grand Total				
Item No.	Description (100meters by 100 meters)	Unit	Quantity	Unit Rate (Kshs)	Total Amount (Kshs)
	Fencing works Fabricate, Deliver and install				
	50mm x 50mm x 2.5mm 6ft galvanized gauge 12.5G minimum wire diameter 2.05mm chainlink with 6 rows of galvanised wire on 100mm x 100mm x 8ft long/high prepainted concrete fencing posts at 3m c-c Note: The tilt must be 300mm at 45 degree with 6 holes (four on the vertical section and two on the 300mm tilth for anchorage of barbed wire to posts. <i>(Rates to include a 150mm thick concrete C15/20) skirting at the fence base)</i>	Mtrs	400		
	Supply,provide and install 100mm x100mm, 8ft long/high concrete poles at 3m spacing C-C <i>(rates to include installation of two corner posts)</i>	Pcs	140		
	Supply,provide and install 100mm x100mm concrete bracing poles	Pcs	21		
	Provide materials,fabricate and install security gate indicated on drawing and as directed by the Engineer. The metallic gate to be painted in 2 coats primer and finished with final coat first grade gloss paint (perch blue). Size 4m x 2.4m high - double leaf with small door inside.	Set	1		
	Allow excavation for the two pillars 0.8m by 0.8m by 1m	m ³	1		

	Provide materials and allow constructions of two reinforced concrete pillars to support the Main gate, concrete gade of M15 at a ratio of mix 1:2:4. The column pillars should have measurement 200mm x 200mm x 2400mm with reinforcement bars of D12 and the ring beam of D8 at a spacing of 200mm.	m ³	0.5	
	<i>Total Brought Forward to collection page</i>			
Nakuron BMU - Box profile				
Item No	Description	Amount		
	Preliminaries & General			
	Dry Fish store			
	Fish cleaning shade			
	Tank Tower			
	Landing Bay			
	Market stalls			
	Twin Latrine			
	Fencing			
	Total			
	10% Contigency			
	Grand Total			

All cost should be Exclusive of VAT

Amount in word.....

Company's Name

Supplier's Name

Address

Signature

GENERAL TERMS AND CONDITIONS

- 1) **Price:** The prices stated on the order shall be held firm for the period and / or quantity unless specifically stated otherwise
- 2) **Source of Instructions:** The Supplier shall not seek nor accept instructions from any source external to SND in relation to the performance of the contract.
- 3) **Assignment:** The Supplier shall not assign, transfer, sublet or subcontract the contract or any part thereof without the prior written consent of the Buyer.
- 4) **Corruption:** The Supplier shall not give, nor offer to give, anyone employed by the Buyer an inducement or gift that could be perceived by others to be a bribe. The Supplier agrees that a breach of this provision may lead to an immediate end to business relationships and termination of existing contracts.

- 5) **Confidentiality:** All data, including but not limited to, maps, drawings, photographs, estimates, plans, reports and budgets that has been compiled by or received by the Supplier under the contract shall be the property of SND and shall be treated as confidential. All such data should be delivered to the authorized officials representing the Buyer upon request.
- a. The Supplier may not communicate at any time to any other person, government or authority external to SND, any information that has been compiled through association with SND which has not been made public except with written authorization from the Buyer. These obligations do not lapse upon termination of the contract.
- 6) **Use of Emblem or Name:** Unless otherwise agreed in writing; the Supplier shall not advertise nor make public the fact that it is supplying goods or services to the Buyer, nor shall the Supplier in any way whatsoever use the name or emblem of SND in connection with its business or otherwise.
- 7) **Observance of Law:** The Supplier shall comply with all laws, ordinances, rules and regulations bearing upon the performance of its obligations under the terms of the contract.
- 8) **Force Majeure:** The meaning of the term can be taken to mean acts of God, war (declared or not), invasion, revolution, insurrection or acts similar in nature or force.
- a. In the event of and as soon as possible after the occurrence of any cause deemed force majeure, the Supplier must inform the Buyer of the full particulars in writing. If the supplier is rendered unable either in part or in whole to perform its obligations then the Buyer shall take such action as it considers, in its sole discretion, to be appropriate or necessary in the circumstances.
- b. If the Supplier is permanently rendered incapable in whole or part by reason of force majeure to complete its obligations and responsibilities under the contract then the Buyer will have the right to suspend or terminate the contract on the same terms and conditions laid out in section 9, Cancellation.
- 9) **Cancellation:** The Buyer reserves the right to cancel the contract should it suspend its activities or through changes to its mandate by virtue of the Executive Council of SND and/or lack of funding. In such a case the Supplier shall be reimbursed by SND for all reasonable costs incurred by the Supplier, including all materials satisfactory delivered and conforming to specification and terms of contract, prior to receipt of the termination notice.
- a. Should the supplier encounter solvency problems including, but not limited to, bankruptcy, liquidation, receivership and similar, the buyer reserves the right to terminate the contract immediately without prejudice to any other right or remedy it may have under the terms of these conditions.
- 10) **Warranty:** The Supplier shall provide the Buyer with all manufacturers' warranties. The supplier warrants that all goods supplied in relation to the contract meets specification, is defect free and is fit for the purpose of the intended use. If, during the warranty period, the goods are found to be defective or non- conforming to specification, the Supplier shall promptly rectify the defect. If the defect is

permanent then at the choice of the Buyer the Supplier will either replace the item at their cost or reimburse the Buyer.

- 11) **Inspection and Test:** The Supplier must inspect the goods prior to dispatch to ensure conformance to specification and/or any other provisions of the contract. The Buyer reserves the right to inspect the goods for compliance with specifications and provisions of the contract. If, in the Buyers' opinion, the goods and/or services do not comply with the specification, the Buyer will inform the Supplier in writing. In such a case the Supplier shall take the necessary action to ensure compliance, liability for any additional cost incurred for rectifying compliance will rest with the Supplier.
- 12) **Changes:** The Buyer reserves the right to make reasonable changes at any time to the specification, drawings, plans, quantity, packing instructions, destination, or delivery instruction. If any such change affects the price of goods or performance of service the Supplier and Buyer may negotiate an equitable adjustment to the contract, provided that the Supplier claims for adjustments in writing to the Buyer within 30 days from being notified of any change.
- 13) **Export Licence:** If export licenses are required for the goods, the Supplier has the responsibility to obtain that license.
- 14) **Payment Terms:** Unless otherwise agreed, payment terms will be net 30 days from receipt of a correctly prepared invoice.
- 15) **Pre-bid meeting:** For all interested and potential bidders, a mandatory pre-bid site meeting will be held at the project site from **Monday, 18th May 2026 to Tuesday 19th May 2026 starting from 8:00 A.M.** Technical staff from SND will be available to respond to any questions related to this tender. Companies intending to participate are required to confirm, share and submit the details of their representative (Full names, I.D numbers and designation) via procurement@sndafrica.org. In case further clarification is needed regarding this tender, please **contact Eng. Joseph Gitu at 0700474055** A signed site attendance certificate will be issued during the pre-bid meeting and will form part of the mandatory requirements for tender submission.
- 16) **Bid Submission:** All bids should be submitted electronically via procurement@sndafrica.org or physically at **SND Moyale office** in a sealed envelope referenced **SND -WFP/LTP-COE Loyangalani BMU/2026-01** as the subject of the Email or on the ENVELOPE **on or before Wednesday, 27th May 2026**

ESSENTIAL REQUIRED DOCUMENTS

The tenderer must attach the following documents to the tender to be submitted;

1. Mandatory Requirements. (Total Score 25 Marks)

- i) Business registration certificate or Certificate of incorporation **(5 Marks)**
- ii). A signed pre-bid meeting site attendance certificate **(5 Marks)**
- iii). CR12 or Copies of ID card in case of a sole proprietorship & partnership Businesses **(2 Marks)**
- iv). Valid Business permit **(2 Marks)**

- v). PIN no & KRA Compliance certificate **(2 Marks)**
- vi). Duly filled, completed and stamped BOQ **(2 Marks)**
- vii). Insurance of works certificate - Contractors to submit insurance of works, materials, equipment workers and third-party beneficiaries. **(5 Marks)**
- viii) Duly signed and stamped certificate of pre-bid site meeting certificate **(2 Marks)**

NB. Only those who provide all the mandatory requirement will proceed to technical evaluation

2. Technical Documents (Total Score 65)

- i). Certificate of registration with at least NCA 7 and Practicing license (preferably building works) - **9 Marks**
- ii.) The lead staff to have a degree in civil or Mechanical engineering from recognized university and proof of registration with Engineers Board of Kenya (Attach CVs & Certificates) and a minimum of 3 years' experience in assignments of similar nature **(5 marks)**
 - b) Technical staff; **(9 Marks)**
 - 1. Site representative - minimum diploma in Civil/Construction management. (Should be on site full time)
 - 2. Welder - minimum 3 years exp. Certificate in welding & fabrication (Attach CVs and Relevant certificates)
 - 3. Mason - minimum 3 years. Certificate in masonry (Attach CVs and Relevant certificates)
- iii) Provide proof of availability of the following equipment **(9 Marks)**
 - 1. Welding gensets (attach proof of ownership/lease)
 - 2. Concrete mixers (attach proof of ownership/lease)
 - 3. Poker vibrator (attach proof of ownership/lease)
 - 4. Hydraulic/electric Jackhammers & Compressors (attach proof of ownership/lease)
- iv). Proof of similar assignments completed at least 3 certificate of completion **(27 Marks)**
- v). Audited Report for the last 2 years or Bank statement for the last 6 Month **(3 Marks)**
- vi). A detailed work plan and implementation schedule for the proposed works **(3 Marks)**

NB. A minimum combined score of 75% in the Mandatory and Technical evaluations must be achieved for a bidder to qualify for the Financial Evaluation stage.

3 Financial evaluation (Total Score 10%)

- Financial evaluation shall be conducted **only for technically qualified bidders.**
- The **lowest-priced quotation** shall receive the **maximum score of 10%.**
- Other bidders shall be scored using the following formula:

Financial Score = (Lowest Quoted Price / Bidder's Price) × 10

Award Decision: The contract will be awarded to the **technically compliant bidder with the most advantageous financial offer.**

For Official Use Only

No.	Name of staff	Designation	Date	Signature
1				
2				
3				
4				
5				

NB Tender to be filled as per the specification given and to be submitted on or before 27th May 2026 via procurement@sndafrica.org or to be delivered to SND offices at Moyale or Marsabit.

NB 2 : The RFQ should be referenced [SND -WFP/ LTP- COE Nakuron BMU/2026- 01](#) as the subject of the Email or on the ENVELOPE

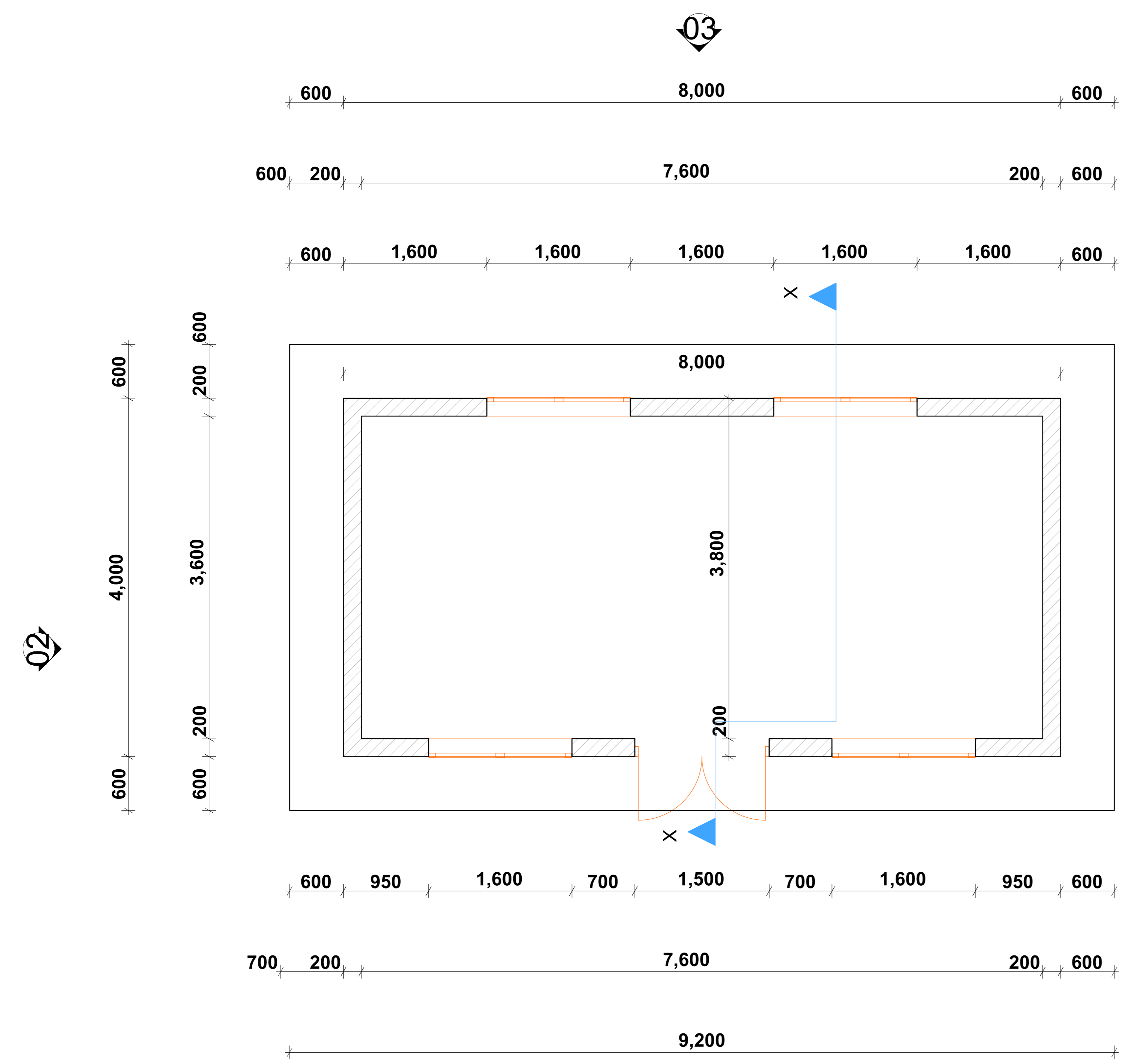

PLAN LAYOUT

Roof pitch-22.5 Deg.. -Gauge 28 roofing sheet on 50X25mm steel Trusses, ,50X25mm purlins @1200mm c/c.

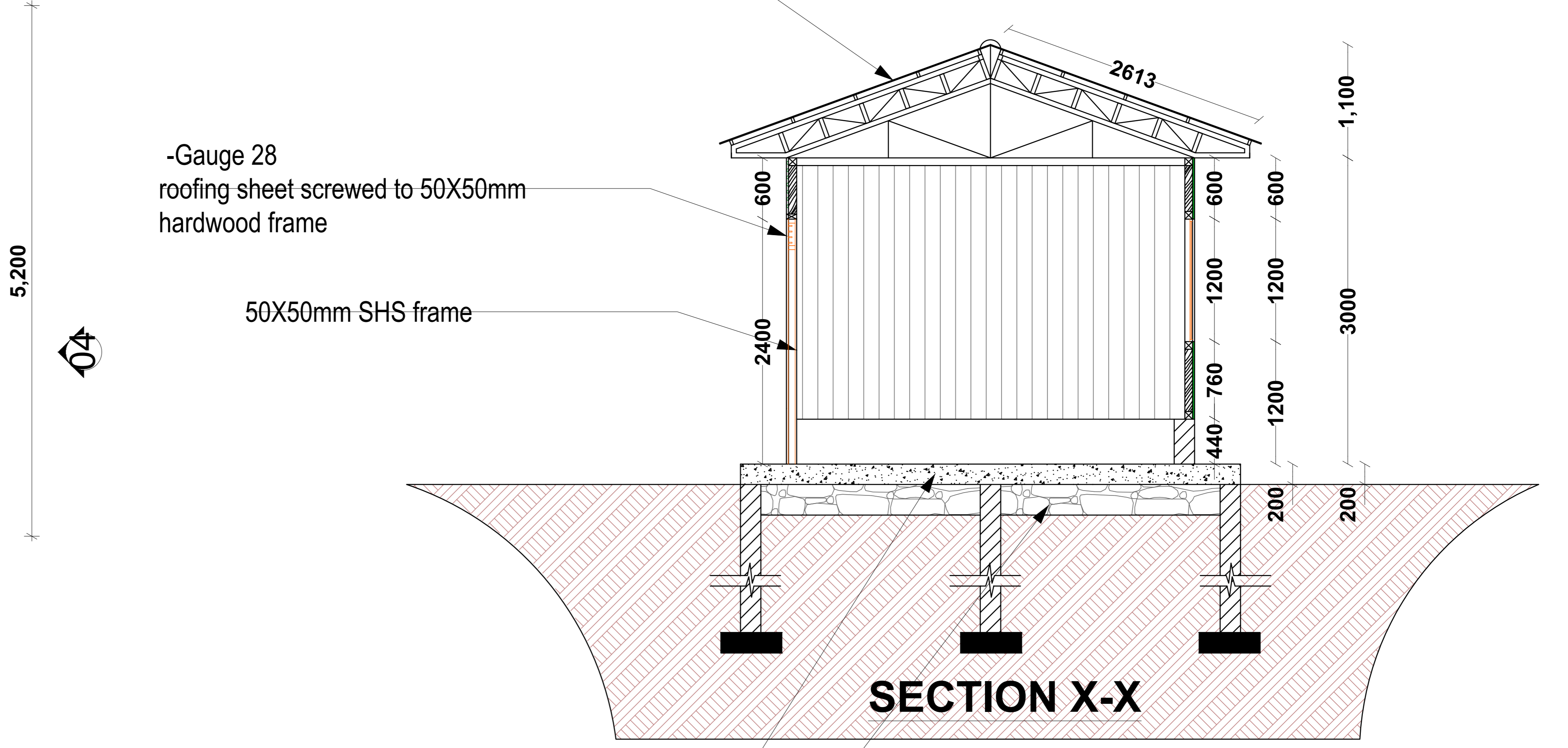

-Gauge 28 roofing sheet screwed to 50X50mm hardwood frame

50X50mm SHS frame

25mm thick sand/cement screed laid on 150mm rc slab to SE's details, ready to receive finish to arch's approval

DPM on 50mm blinding on 300mm well compacted anti-termite treated hardcore

SECTION X-X

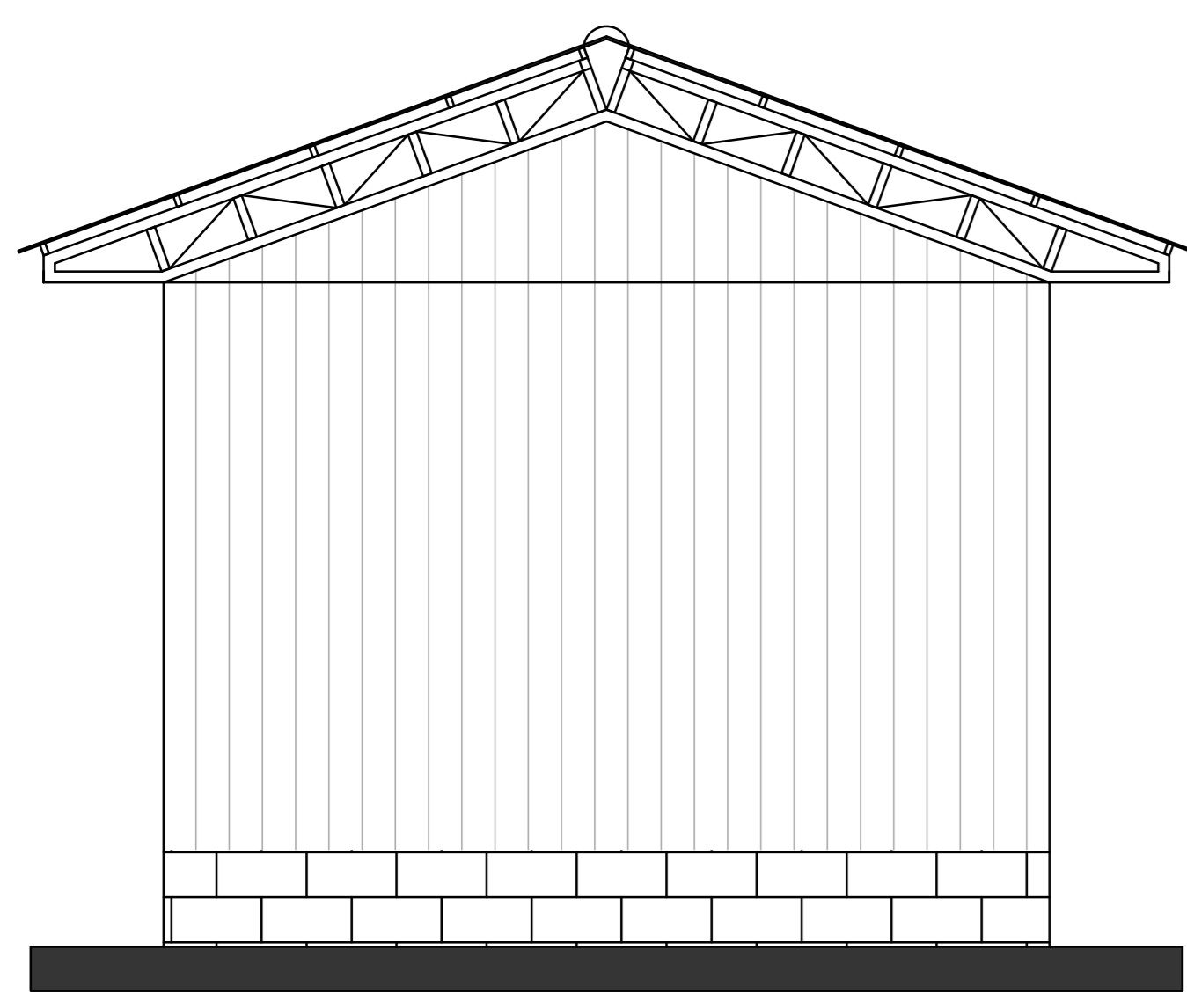

ELEVATION 01

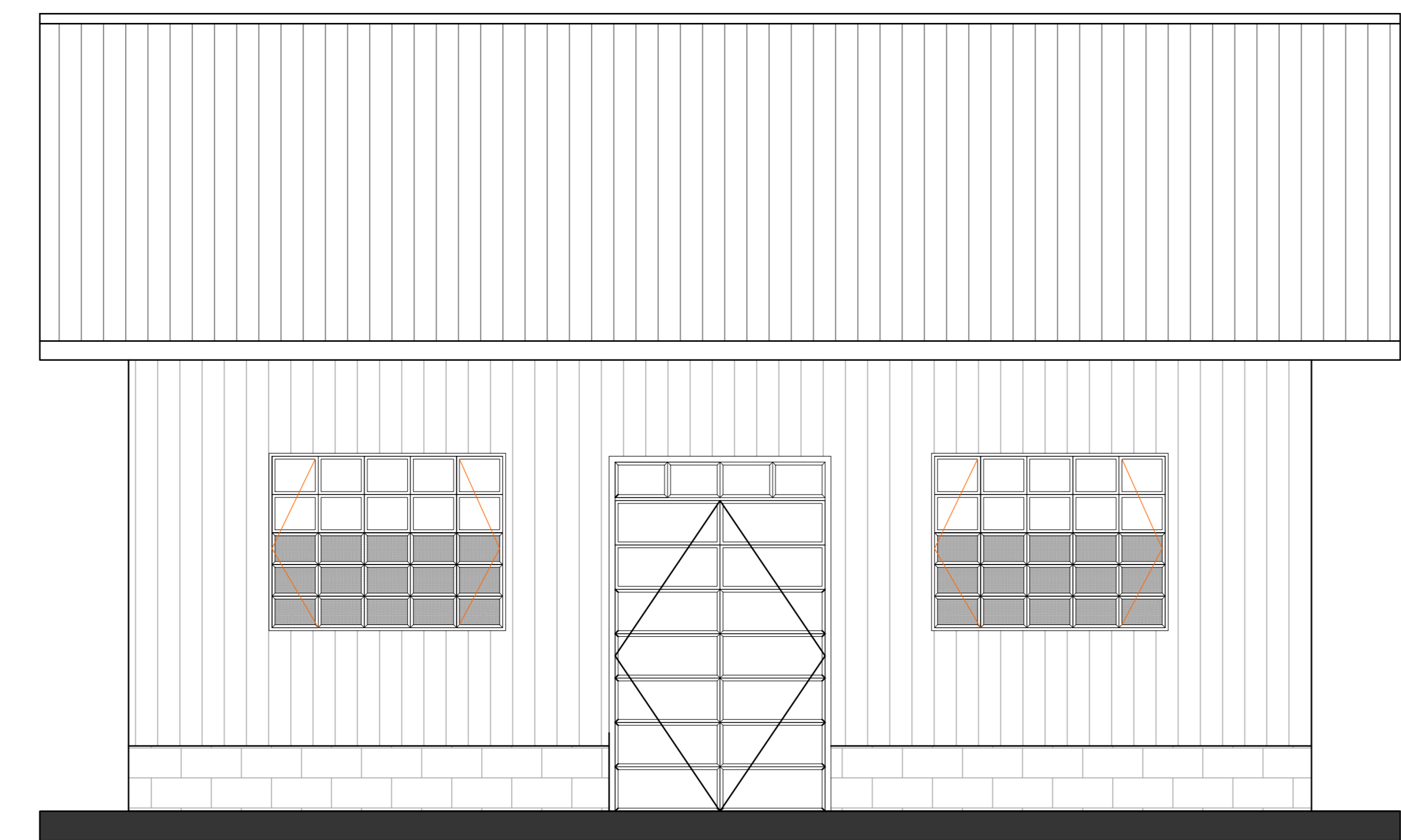

ELEVATION 02

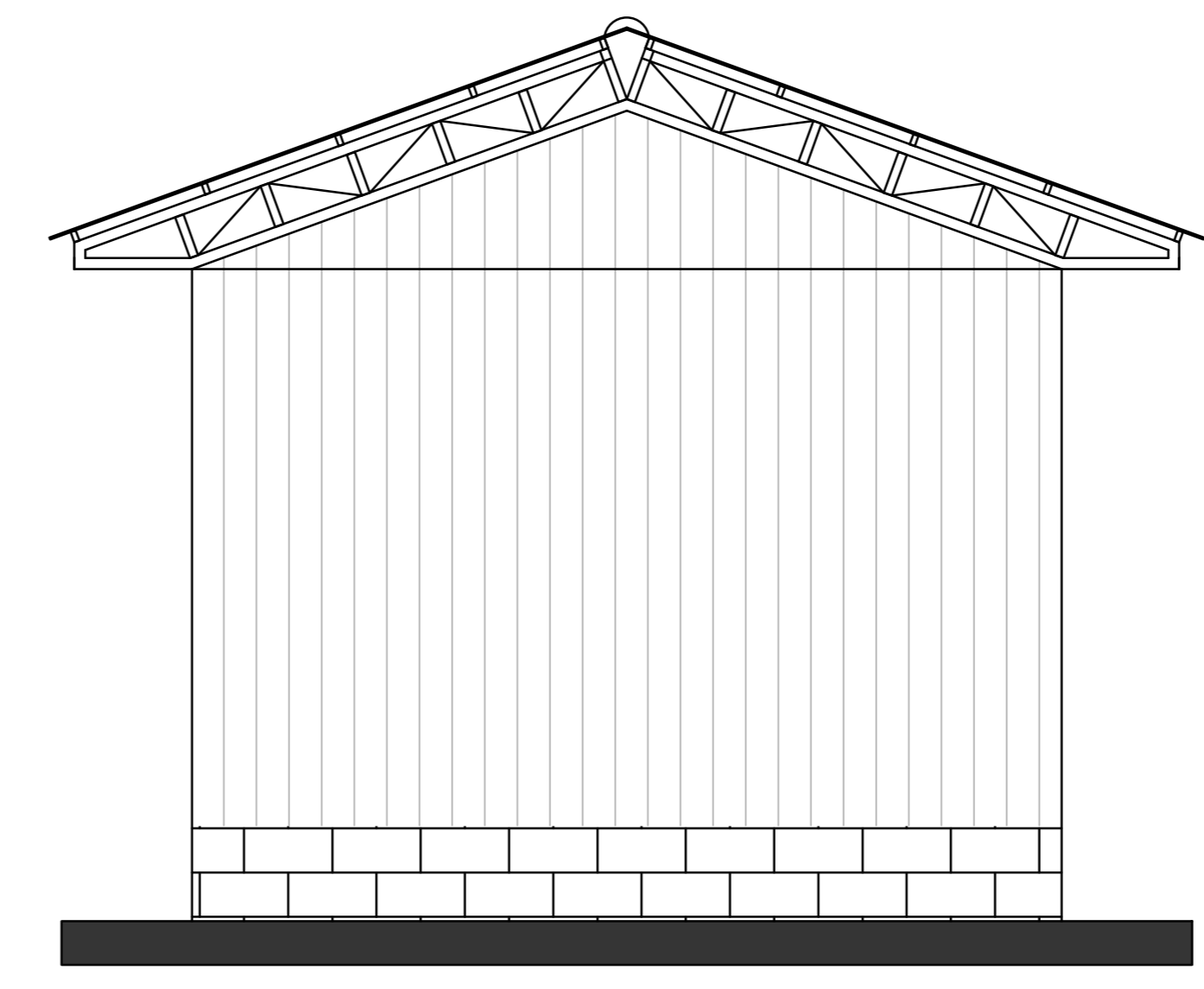

ELEVATION 03

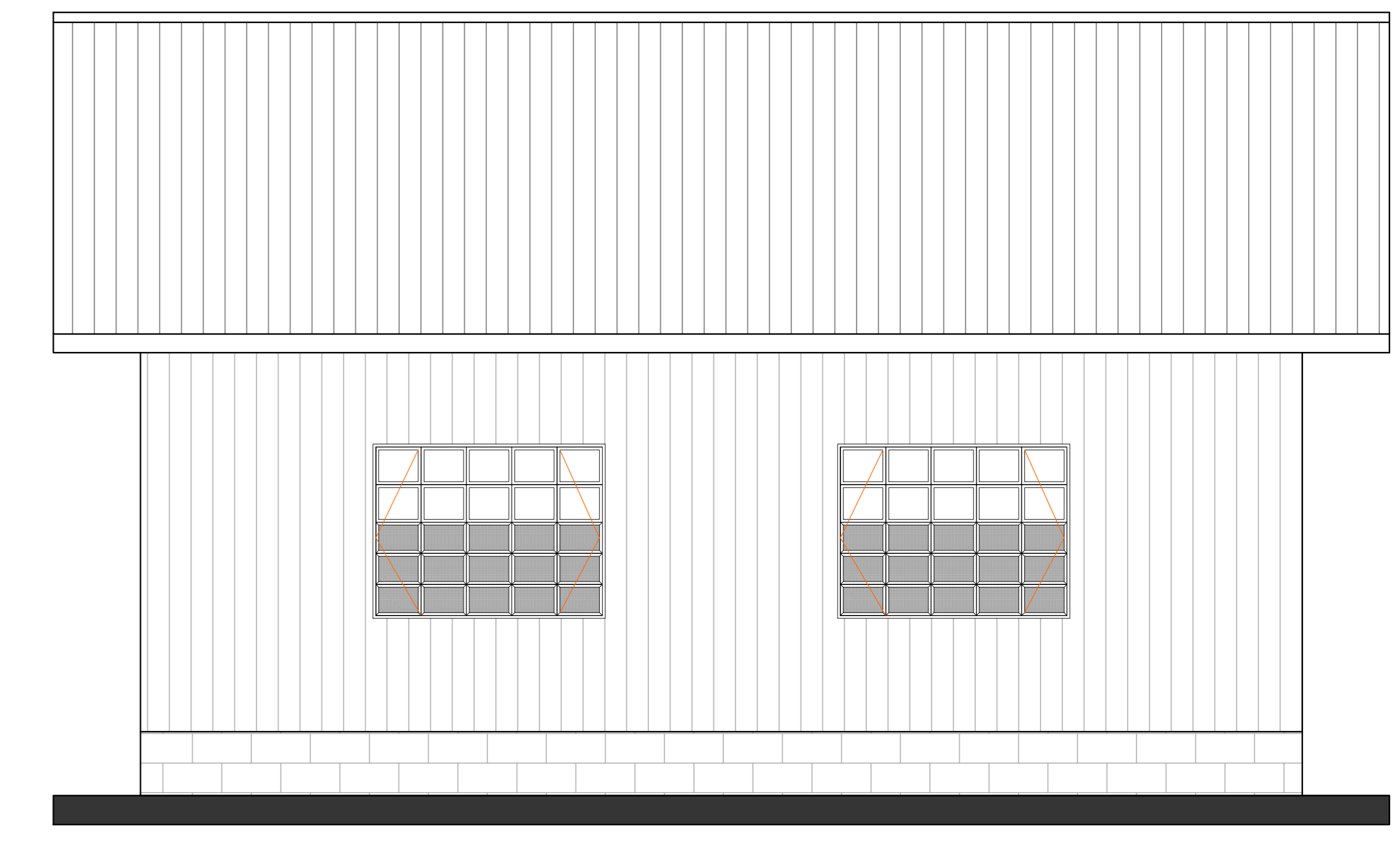

ELEVATION 04

CONSULTANT	REV NO.	DESCRIPTION	DATE	CLIENT	PROJECT DETAILS		Date:	Job No:
					PROJECT TITLE:	Sustainably Unlocking the Economic Potential of Lake Turkana Programme	Designed:	
					DRAWING TITLE:	Nakuron BMU - Dry Fish store	Drawn:	Cad File Name
							Checked:	
							Approved:	DWG. No.
							Scale:	Rev. No.

WFP/SND/Nakuron - D.S/ 052025-01

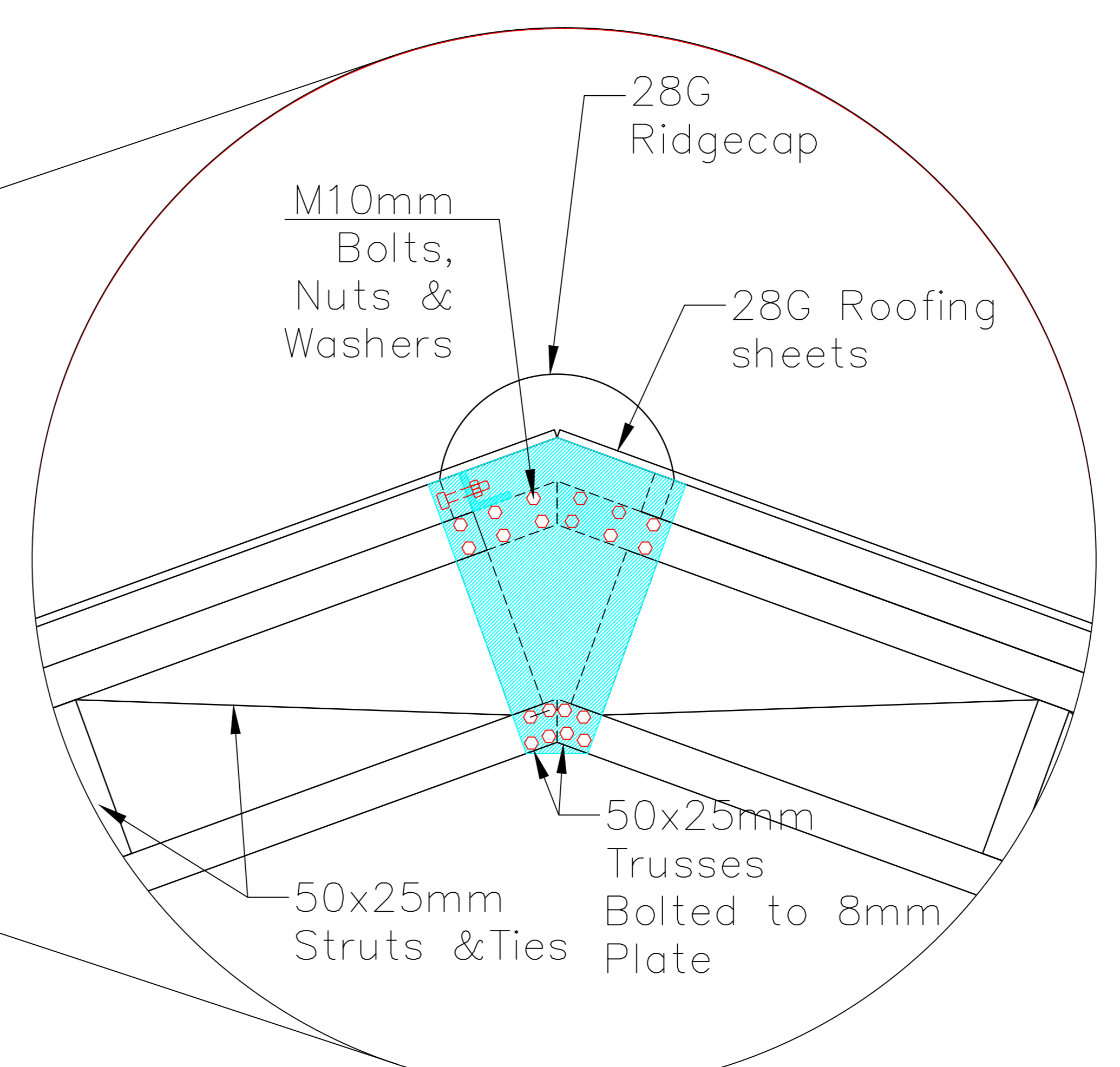
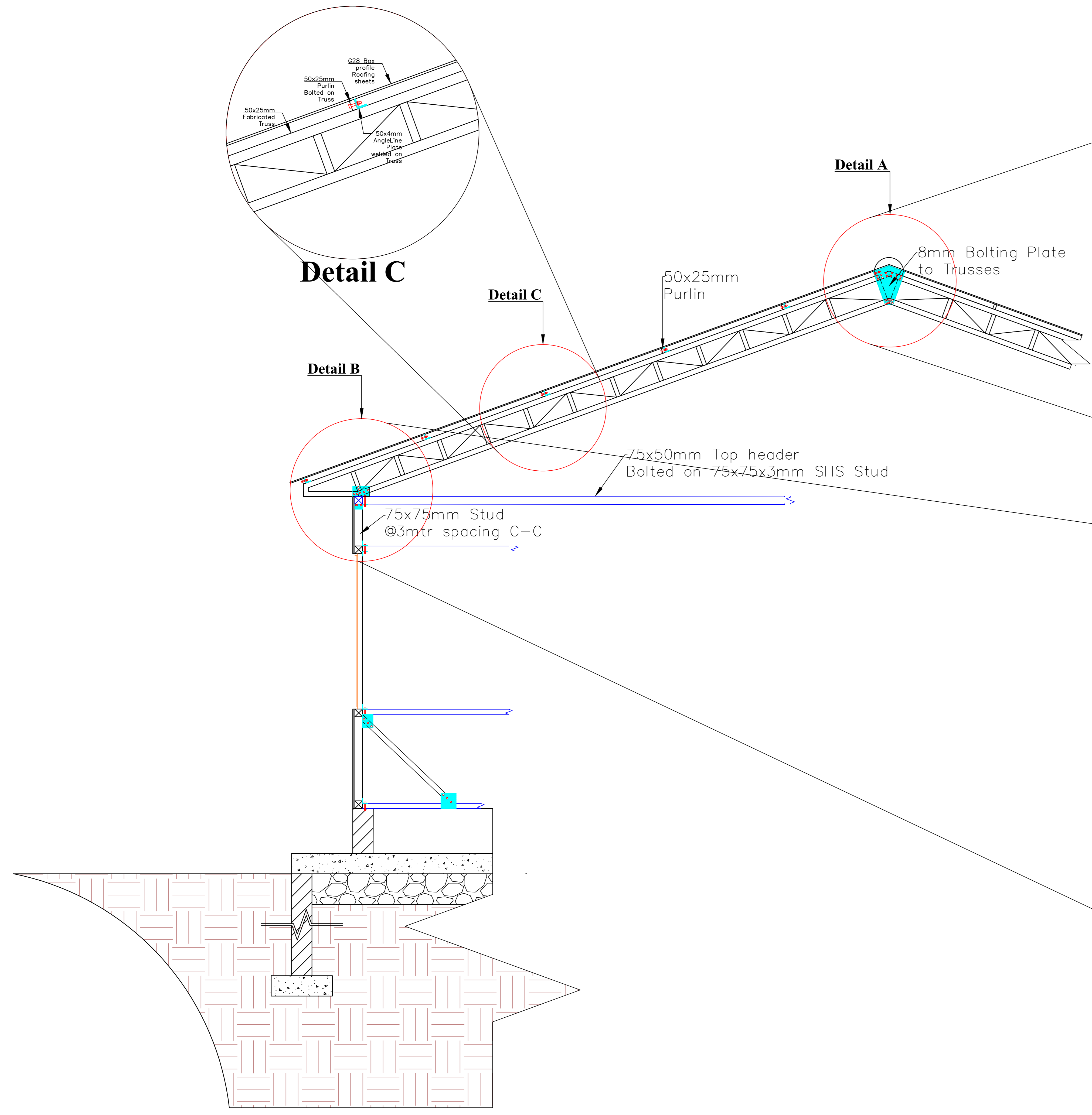

Detail A

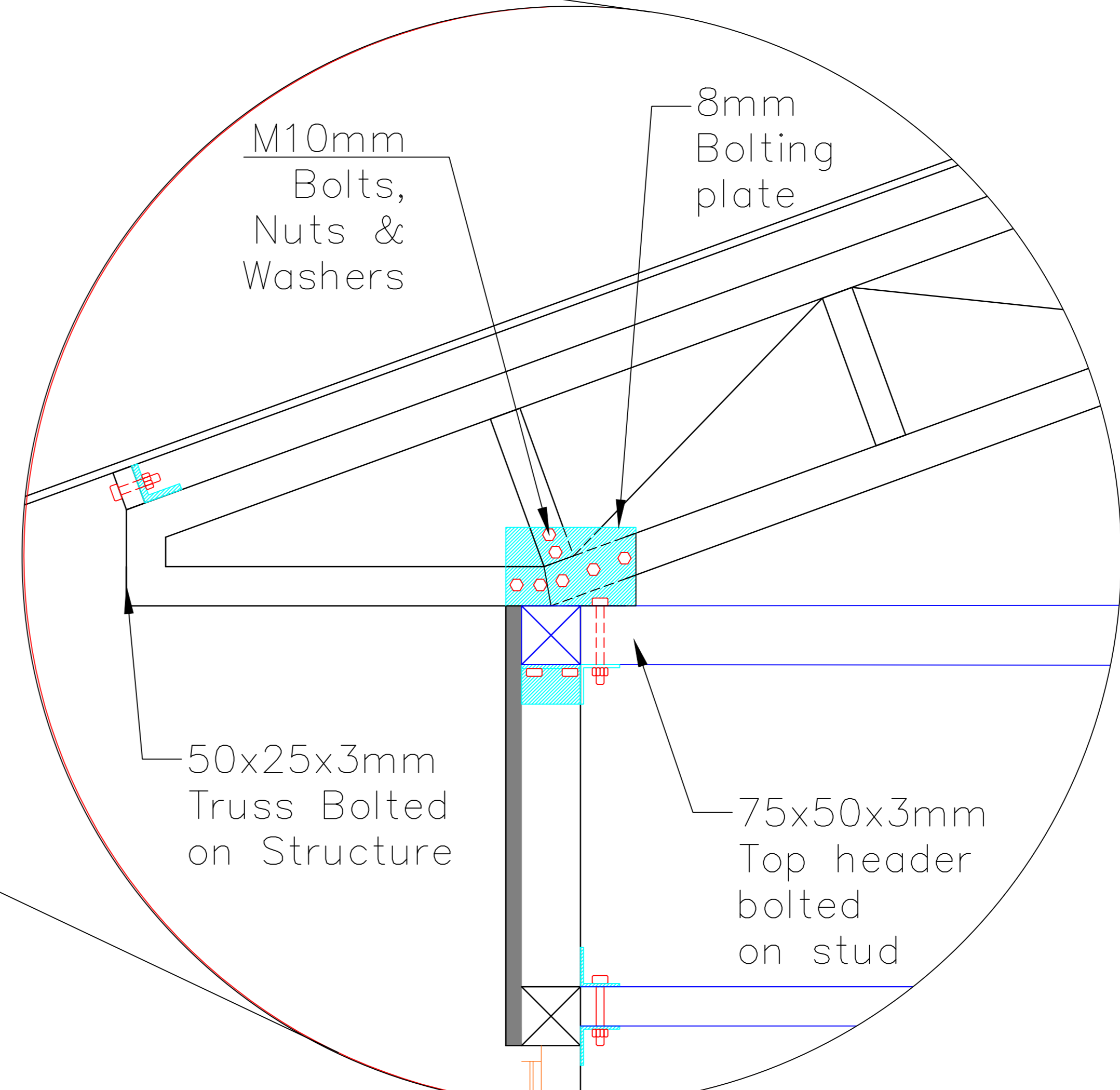

Detail B

CONSULTANT	REV NO.	DESCRIPTION	DATE	CLIENT	PROJECT DETAILS		Date:	Job No:
					PROJECT TITLE:	Sustainably Unlocking the Potential of Lake Turkana Project	Designed:	
					DRAWING TITLE:	Dry Fish Store Roof Details	Drawn:	Cad File Name
							Checked:	
							Approved:	DWG. No.
							Scale:	Rev. No.
								WFP/SND/LTP/ Lyng DS 04-4

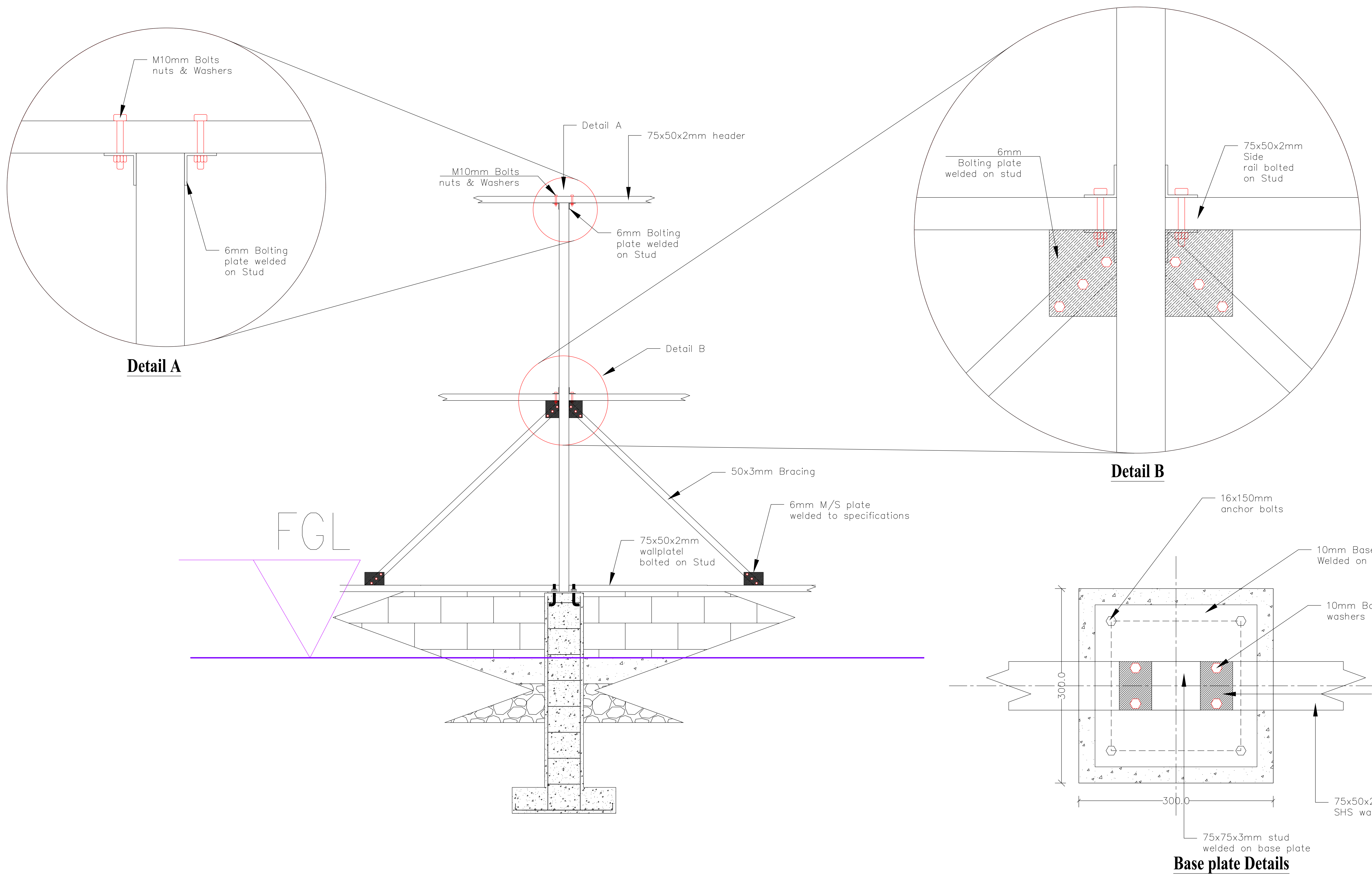

Detail A

Detail B

Base plate Details

CONSULTANT	REV NO.	DESCRIPTION	DATE	CLIENT	PROJECT DETAILS		Date:	Job No:
					PROJECT TITLE:	Sustainably Unlocking the Potential of Lake Turkana Project	Designed:	
					DRAWING TITLE:	Dry Fish Store Fabrication Details	Drawn:	Cad File Name
							Checked:	
							Approved:	DWG. No.
							Scale:	Rev. No.
								WFP/SND/LTP/ Lyng DS 03-4

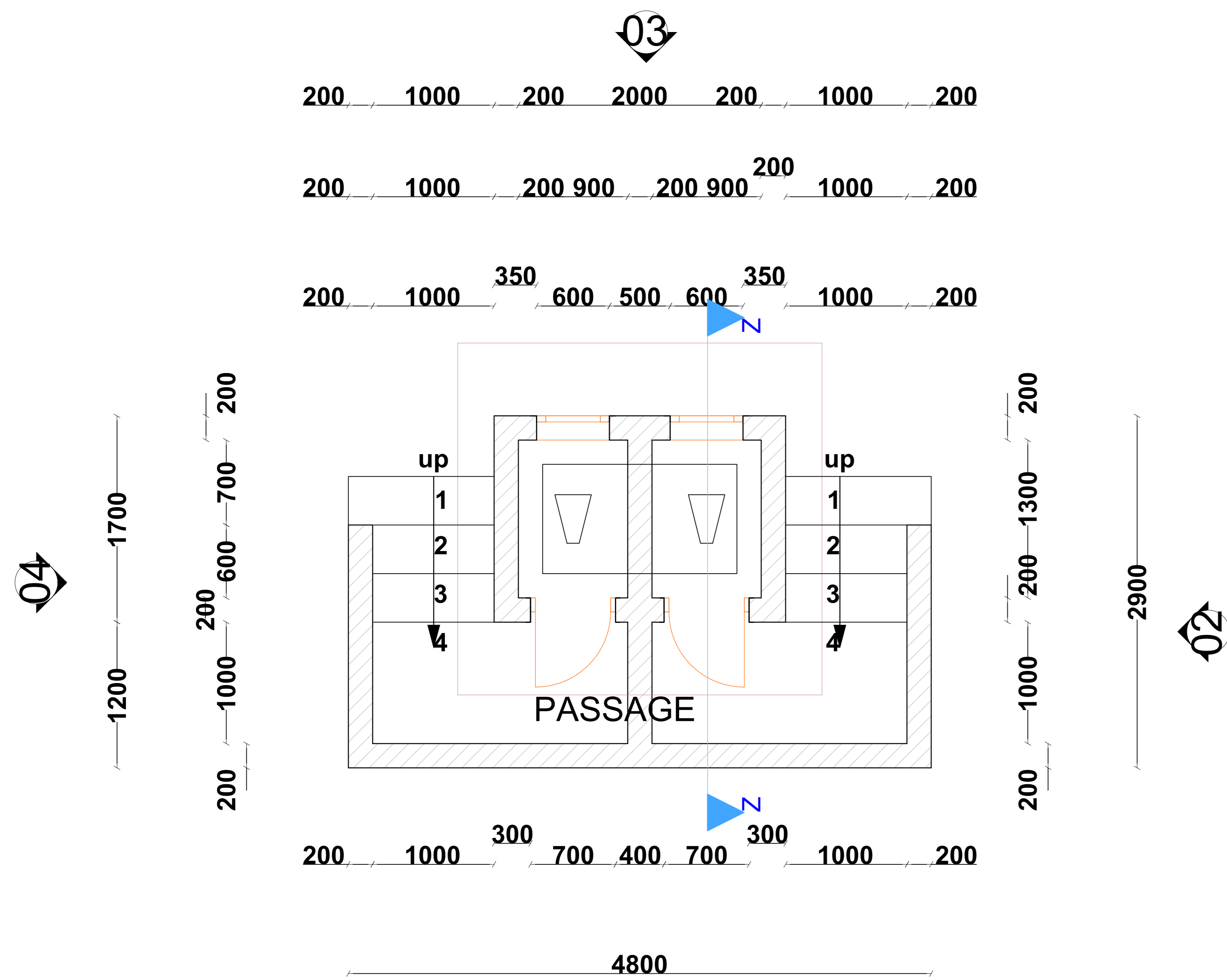

PLAN LAY OUT

Roof pitch- 8 Deg.. -Gauge 30 roofing sheet on 75X50 rafters, 50X50mm purlins@ 1250 mm c/c on 75X50 mm wallplate.

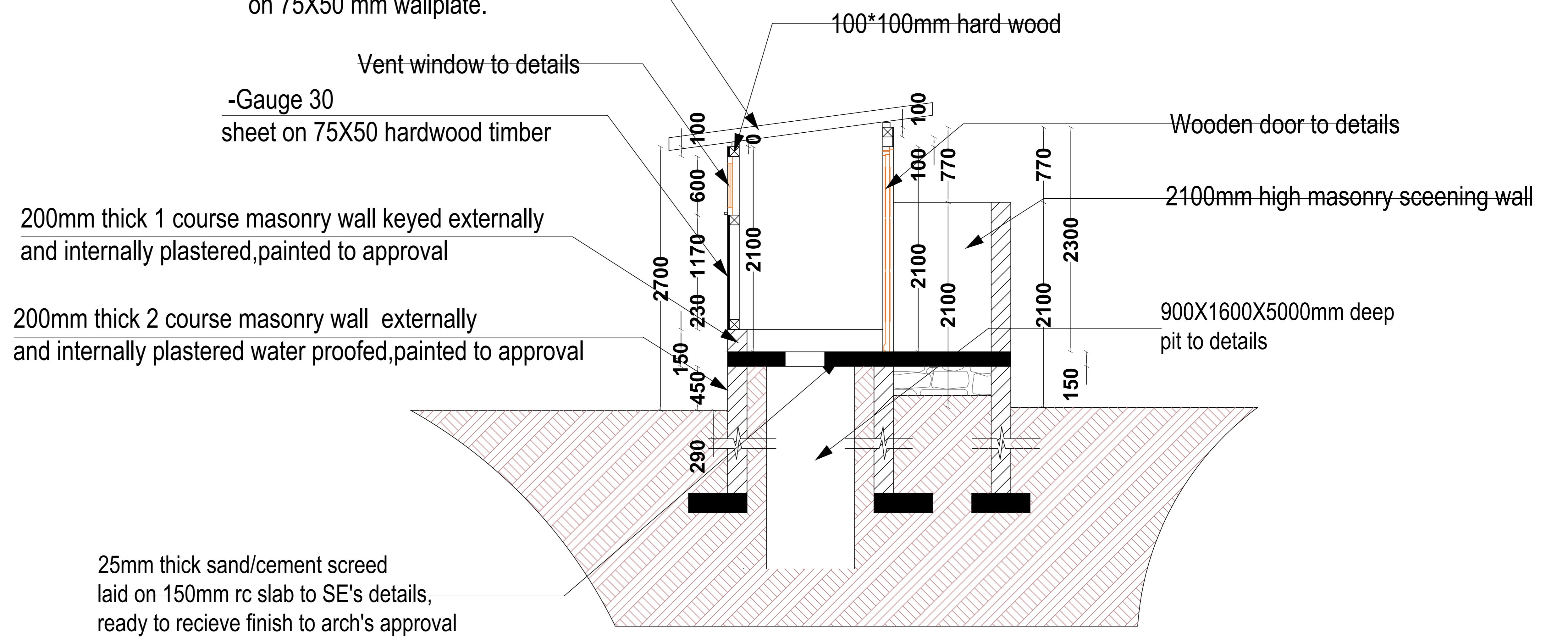

SECTION X-X

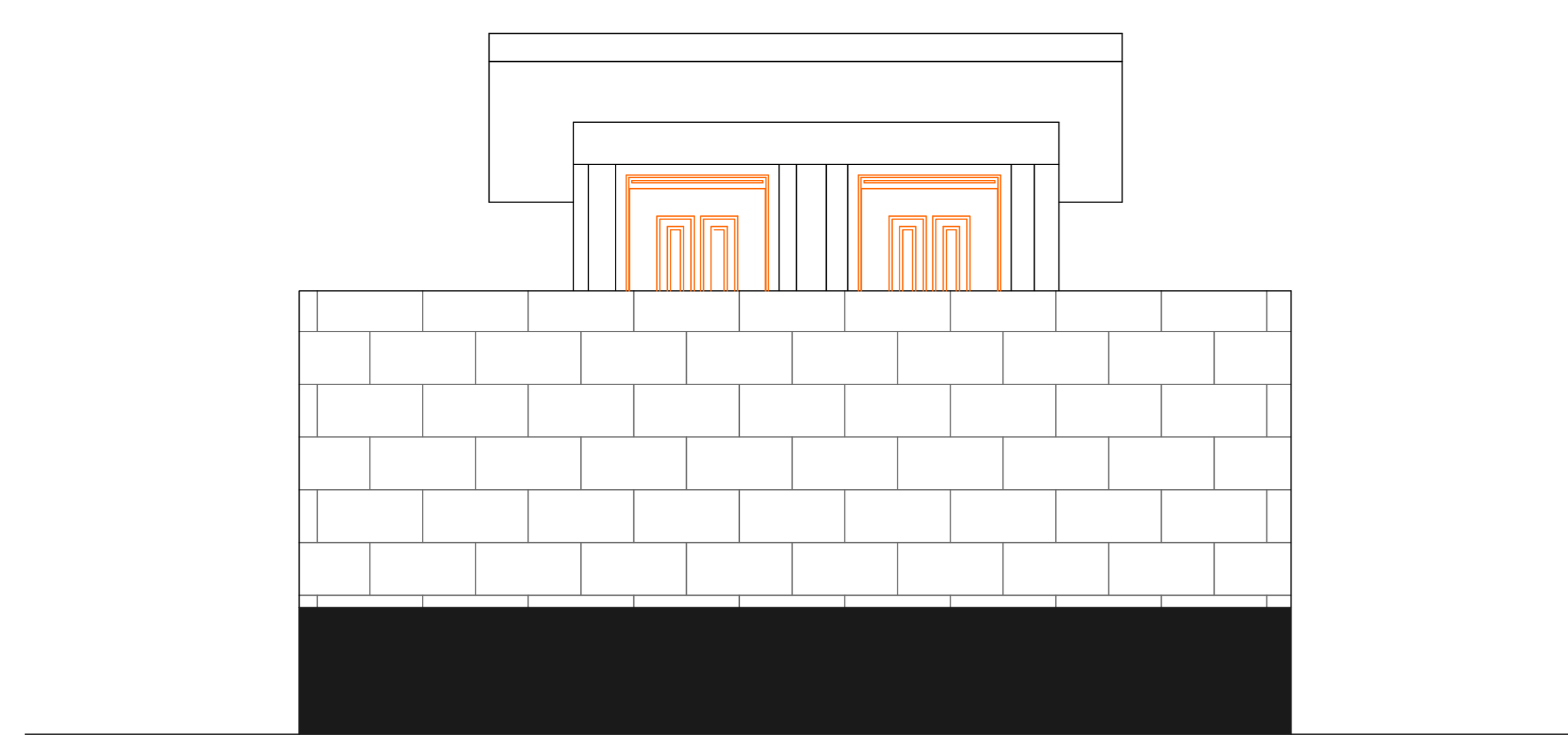

ELEVATION 01

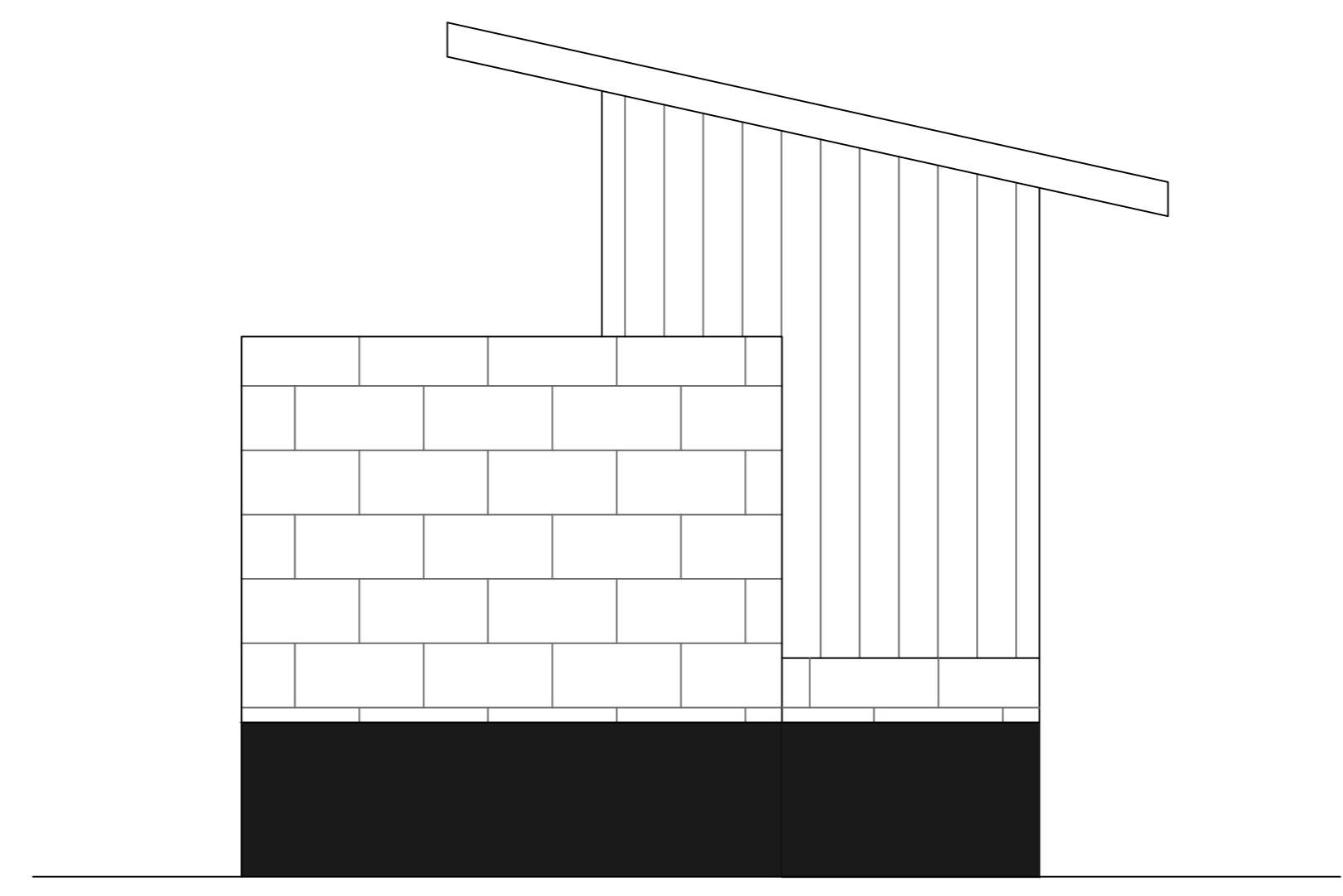

ELEVATION 02

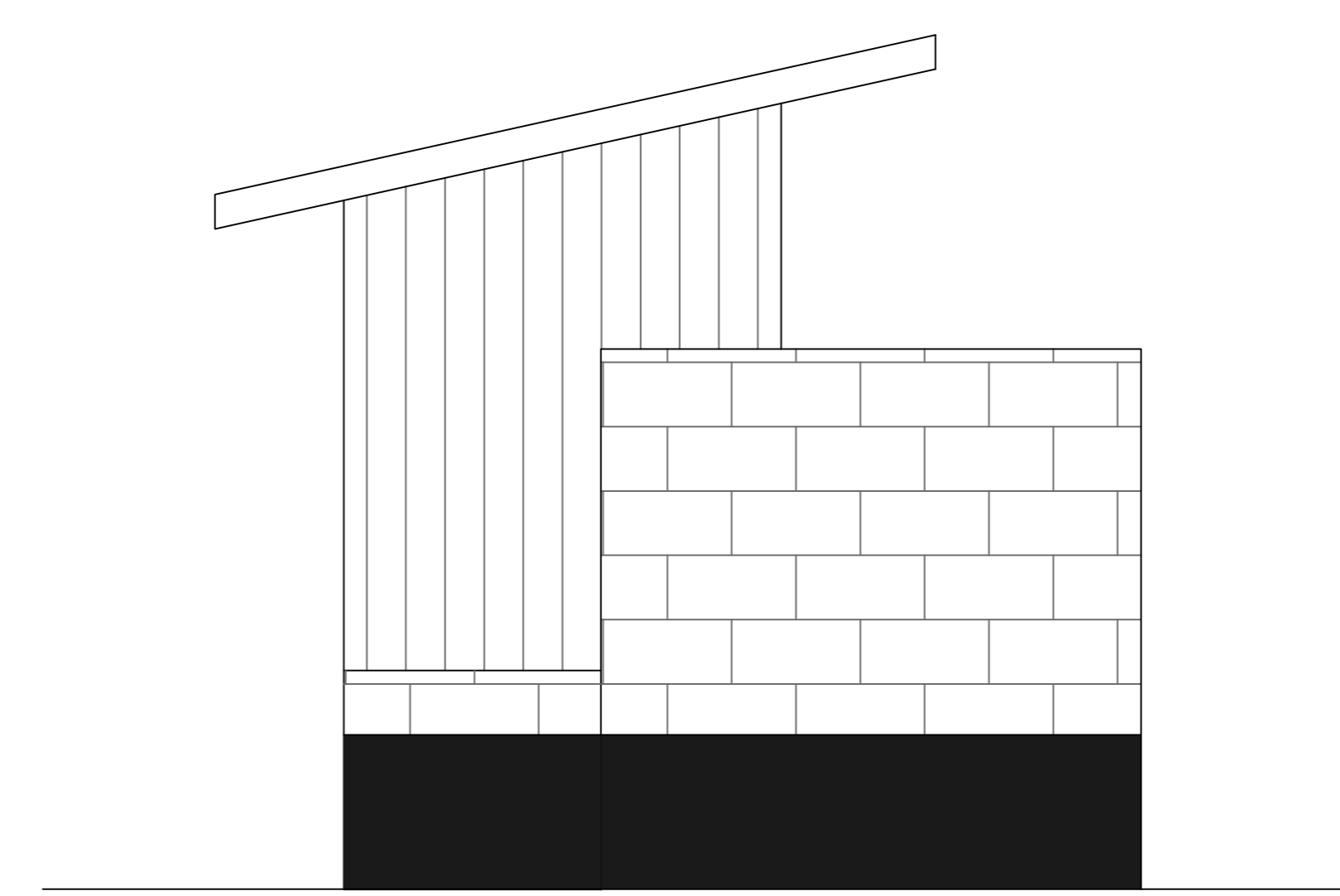

ELEVATION 02

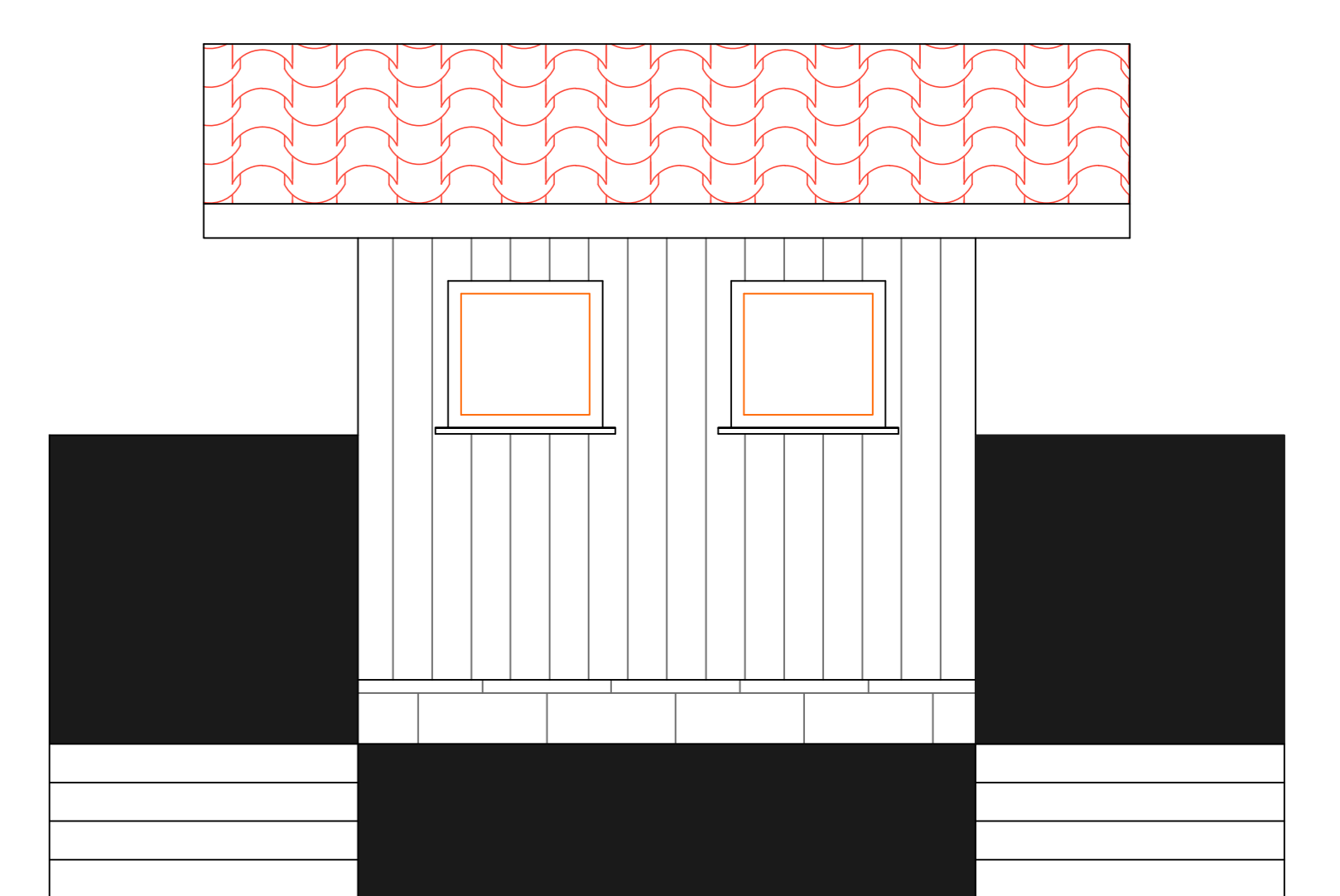

ELEVATION 03

CONSULTANT	REV NO.	DESCRIPTION	DATE	CLIENT	PROJECT DETAILS		Date:	Job No:
					PROJECT TITLE:	Sustainably Unlocking the Economic Potential of Lake Turkana Programme	Designed:	
					DRAWING TITLE:	Proposed Latrine	Drawn:	Cad File Name
							Checked:	
							Approved:	DWG. No.
							Scale:	Rev. No.
								WFP/SND/Pic Lat-01