



STRATEGIES FOR NORTHERN DEVELOPMENT (SND) – KENYA

TENDER DOCUMENT TO SUPPORT SUPPLY, FABRICATION & INSTALLATION OF SHADENETS, SHADENET STRUCTURES AND DRIP IRRIGATION SYSTEMS TO TWO WOMEN GROUPS IN DUKANA VILLAGE

HARRY THUKU LANE, OFF MARSABIT GENERAL HOSPITAL ROAD, BEHIND CATHOLIC CHURCH-MARSABIT

OFF WILDLIFE ROAD, ADJACENT TO KENYA NATIONAL LIBRARY.

Tel: [+254] 741845578

E-mail: info@sndafrica.org

Website: www.sndafrica.org

REF: [SND -PIK/ 10 /2025- 001](#)

Closing Date: 8th April 2024

TENDER INVITATION

Re: SUPPLY, FABRICATION & INSTALLATION OF SHADENETS, SHADENET STRUCTURES AND DRIP IRRIGATION SYSTEMS TO TWO WOMEN GROUPS IN DUKANA VILLAGE

The Strategies for Northern Development (SND), is a local non-governmental organization working with nomadic pastoralist communities in Northern Kenya and Southern Ethiopia. SND was registered in Kenya with the NGO Coordination Board as a fully-fledged NGO on 6th December 2007.

SND is driven by a vision to see a society where all pastoralist communities are resilient and live a dignified life and a mission to empower and transform pastoralist communities to be self-resilient in life. Key thematic areas of focus are;

- i. Peace, Conflict Resolution and Governance
- ii. Humanitarian Assistance and Emergency Response
- iii. Protection, Gender Equality and Inclusion
- iv. Climate Justice and Resilience
- v. Livelihood and Enterprise Development
- vi. Water, Sanitation, and Hygiene (WASH).
- vii. Institutional Effectiveness

SND has secured funding from Plan International and intends to **supply, fabrication & installation of shade nets, shade net structures and drip irrigation systems to two women groups in Dukana village**

For this purpose, we hereby, invite bidders to submit quotations for the execution and completion of the above assignments as provided in the tender document.

DESCRIPTION OF WORK/SERVICE

GIRLS IN CRISIS IN DUKANA VILLAGE, DUKANA WARD, NORTH HORN SUB COUNTY MARSABIT COUNTY					
SUPPLY, FABRICATION & INSTALLATION OF SHADENETS, SHADENET STRUCTURES AND DRIP IRRIGATION SYSTEMS TO TWO WOMEN GROUPS IN DUKANA VILLAGE					
Item No	Description	U.O.M	Qty	Rates	Total Amount
	<u>Dukana Women self help group 1</u>				
1.1	3m³ plastic tank & Associated plumbing works Supply, Delivery & Installation of 3m ³ Plastic Storage Tank, installation of all pipework, fittings and specials in accordance to the contract drawings. Tank should include a OD40 mm Inlet provision, OD 40mm Overflow provision & Tank Interconnection provision, walls should be corrugated, One-piece molding with no joints, leak-proof and should be able to withstand harmful effects of sunlight preferably Ken tank/Roto tank	Pcs	1		

2	Elevated tank structure				
2.1	Supply, fabricate and install a 2 mtr above ground level silver painted elevated steel tank structure comprised of access ladder, Guard rails 4 No 50mm x 50mm x 3mm SHS stanchions embedded in C20/20 Concrete, 50mm x 50mm x 3mm Primary beam, 50mm x 50mm x 3mm Secondary beam, horizontal and diagonal bracing	Ls	1		
3	Shade net (shade net joints should be machine sewn and fastened to the shade net structure using locking profile & Wire)				
3.1	Supply Deliver, fabricate and install a black painted 12mtrs x 12 mtrs x 2.5 mtrs above ground level black painted shade net structure comprised of 50mm x 50mm x 2mm SHS stanchions with 0.6mtrs BGL embedded in C20/20 concrete spaced at 3 mtrs with 50mm x 2mm angle line diagonal bracings, 40mm x 40mm x 2mm bottom, middle and top horizontal bracings. include a 2.5mtrs x 0.9mtrs access door	Ls	1		
3.2	Supply, deliver and install a 75% shade net on 12mtrs x 12mtrs x 2.5mtrs structure	Sqm	370		
3.3	Locking profile & W-wire	Mtrs	170		
4	Piping and Fittings				
	<i>Supply deliver, Excavate, lay, backfill and install the following:</i>				
4.1	Tank outlet Fittings				
	OD 32mm Tank Connector	Pcs	1		
	1" GI socket	Pcs	1		
	32mm HDPE Male adaptor	Pcs	6		
	32mm HDPE Compression Elbow 90 ⁰	Pcs	2		
	1" ball valve (<i>Pegler or equivalent</i>)	Pcs	1		
	1" GI long nipple	Pcs	2		
	1" GI Socket	Pcs	2		
	1" GI Union	Pcs	1		
	1" screen filter	Pcs	1		
	32mm PN 8 HDPE Pipe	Mtrs	20		
	1" GI end caps	Pcs	2		
4.2	Tank inlet Fittings				
	63mm x 11/4" Compression elbow				
	40mm GI Long nipple	Pcs	3		
	40mm backnut	Pcs	2		
	11/4" Ball valve (<i>Pegler of equivalent</i>)	Pcs	1		
	40mm GI Pipe	Mtrs	3		
4.3	Drip line & Fittings				
	<i>Supply, deliver and install the following:</i>				
	16mm safe rubbers	Pcs	35		
	16mm start connectors	Pcs	35		
	16mm PE Pipe	Pcs	35		
	16mm PE -Drip	Pcs	35		
	16mm, 1.2lph 30cm spacing drip line	Mtrs	525		
	16mm End lines	Pcs	35		
	Drip-drip connectors	Pcs	35		
	16mm straight valve	pcs	35		
	<u>Dukana Women self-help group 1 Subtotal</u>				
5	Farm Tools & Equipment				
	<i>Supply, deliver and Train Beneficiaries on usage of the following:</i>				

	20 Liters Knapsack Sprayer	Pcs	1		
	Spades	Pcs	4		
	Fork Hoe c/w Handle	Pcs	4		
	panga	Pcs	2		
	Rake	Pcs	4		
	Wheelbarrow	Pcs	2		
	3/4" x 50mtrs Irrigation Hose pipe	Rolls	1		
	watering can	pcs	4		
	<u>Dukana Women self-help group 1 Subtotal</u>				
	<u>Dukana Women self-help group 2</u>				
1	3m3 plastic tank & Associated plumbing works Supply, Delivery & Installation of 3m ³ Plastic Storage Tank, installation of all pipework, fittings and specials in accordance to the contract drawings. Tank should include a OD40 mm Inlet provision, OD 40mm Overflow provision & Tank Interconnection provision, walls should be corrugated, One-piece molding with no joints, leak-proof and should be able to withstand harmful effects of sunlight preferably Ken tank/Roto tank	Pcs	1		
2	Elevated tank structure				
2.1	Supply, fabricate and install a 2 mtr above ground level silver painted elevated steel tank structure comprised of access ladder, Guard rails 4 No 50mm x 50mm x 3mm SHS stanchions embedded in C20/20 Concrete, 50mm x 50mm x 3mm Primary beam, 50mm x 50mm x 3mm Secondary beam, horizontal and diagonal bracing and the same type of beams should be used to support the tank	Set	1		
3	Shade net <i>(shade net joints should be machine sewn and fastened to the shadenet strucure using locking profile & Wire)</i>				
3.1	Supply Deliver, fabricate and install a black painted 12mtrs x 12 mtrs x 2.5 mtrs above ground level black painted shade net structure comprised of 50mm x 50mm x 2mm SHS stanchions with 0.6mtrs BGL embedded in C20/20 concrete spaced at 3 mtrs with 50mm x 2mm angle line diagonal bracings, 40mm x 40mm x 2mm bottom, middle and top horizontal bracings. include a 2.5mtrs x 0.9mtrs access door	Set	1		
3.2	Supply, deliver and install a 75% shadenet on 12mtrs x 12mtrs x 2.5mtrs structure	Sqm	370		
3.3	Locking profile & W-wire	Mtrs	170		
4	Piping and Fittings				
	<i>Supply deliver, Excavate, lay, backfill and install the following:</i>				
4.1	Tank outlet Fittings				
	OD 32mm Tank Connector	Pcs	1		
	1" GI socket	Pcs	1		
	32mm HDPE Female adaptor	Pcs	6		
	32mm HDPE Compression Elbow 90 ⁰	Pcs	2		
	1" GI long nipple	Pcs	2		
	1" GI Socket	Pcs	2		
	1" GI Union	Pcs	1		
	1" screen filter	Pcs	1		
	32mm PN 8 HDPE Pipe	Mtrs	20		
	1" GI end caps	Pcs	2		

	1" GI pipe	Mtrs	3		
4.2	Tank inlet Fittings				
	<i>Supply, deliver and install the following:</i>				
	63mm x 1 1/4" Compression elbow	Pcs	1		
	40mm GI Long nipple	Pcs	1		
	40mm backnut	pcs	2		
	1 1/4" Ball valve (<i>Pegler of equivalent</i>)	Pcs	1		
	40mm GI Pipe	Mtrs	3		
	<u>Dukana Women self-help group 2 Subtotal</u>				
4.3	Drip line & Fittings				
	<i>Supply, deliver and install the following:</i>				
	16mm safe rubbers	Pcs	35		
	16mm start connectors	Pcs	35		
	16mm PE Pipe	Pcs	35		
	16mm PE -Drip	Pcs	35		
	16mm, 1.2lph 30cm spacing drip line	Mtrs	525		
	16mm End lines	Pcs	35		
	Drip-drip connectors	Pcs	35		
5	Farm Tools & Equipment				
	<i>Supply, deliver and Train Beneficiaries on usage of the following:</i>				
	20 Liters Knapsack Sprayer	Pcs	1		
	Spades	Pcs	4		
	Fork Hoe c/w Handle	Pcs	4		
	panga	Pcs	2		
	Rake	Pcs	4		
	Wheelbarrow	Pcs	2		
	3/4" x 50mtrs Irrigation Hose pipe	Rolls	1		
	watering can	Pcs	4		
	<u>Dukana Women self-help group 2 Subtotal</u>				
	<u>Preliminary works</u>				
1	Fencing <i>(include rates for concrete skirting at the base of the fence perimeter)</i>				
1.1	Provide perimeter fence made of 50mm x 50mm x 4mm angle lines and Chain-link of wire diameter not less than 2.05mm, galvanized and 6 strands of galvanized wire as per Standard Drawings	Mtrs	120		
1.2	3 meter wide double leaf gate as per the standard drawings	Set	2		
2	Project signboard				
2.1	Fabricate, Deliver a project signboard as specified by the client. <i>(Logos and artwork design will be provided by the client)</i>	Set	2		
3	PIPE WORK - PIPES				
	<u>Provide and Lay</u>				

	Provide (incl purchase, storage and transportation), lay and joint pipes in trench, include for excavation in normal material, preparation of surfaces, disposal of excavated material, dewatering, shoring sides of excavation and backfilling with suitable selected excavated material. Note:- Trench width and minimum cover to pipes is as per the Specification. The cost shall include for strutting, shuttering, stabilizing the earth faces of trenches and keeping the trenches free of water from whatever source by pumping or other means and cost of use of selected soil from the excavated material for compaction in bed and surround to backfilling of trenches, all as specified.				
	<u>Provide and Lay 'High Density Polyethylene ' (HDPE) PN10 (Compression fittings)</u>				
	OD 63 mm in trench, depth not exceeding 1 m (Note, the rate will include trenching, laying of the HDPE Pipes and backfilling.	Mtrs	100		
	OD 63mm female adaptors	Pcs	3		
	DN 50mm GI tee	Pcs	1		
	DN 50mm Hex nipple	Pcs	4		
	DN 50mm union	Pcs	2		
	DN 50mm Gate valve	Pcs	3		
	DN 50mm Socket	Pcs	2		
	Provide all materials and construct CONTROL VALVE chambers internal dimensions 1000mm x 1000mm. Include for supply and fixing of 600mm x 600mm lockable cover and step irons	Set	1		
	Preliminary works Subtotal				
	<i>Balance brought to collection</i>				
	Dukana Women self-help group 1				
	Dukana Women self-help group 2				
	Preliminary works				
	Total				
	16% VAT				
	Grand Total				

Amount in word.....

Company's Name

Supplier's Name

Address

Signature

GENERAL TERMS AND CONDITIONS

- 1) **Price:** The prices stated on the order shall be held firm for the period and / or quantity unless specifically stated otherwise
- 2) **Source of Instructions:** The Supplier shall not seek nor accept instructions from any source external to SND in relation to the performance of the contract.
- 3) **Assignment:** The Supplier shall not assign, transfer, sublet or subcontract the contract or any part thereof without the prior written consent of the Buyer.
- 4) **Corruption:** The Supplier shall not give, nor offer to give, anyone employed by the Buyer an inducement or gift that could be perceived by others to be a bribe. The Supplier agrees that a breach of this provision may lead to an immediate end to business relationships and termination of existing contracts.

- 5) **Confidentiality:** All data, including but not limited to, maps, drawings, photographs, estimates, plans, reports and budgets that has been compiled by or received by the Supplier under the contract shall be the property of SND and shall be treated as confidential. All such data should be delivered to the authorized officials representing the Buyer upon request.
 - a. The Supplier may not communicate at any time to any other person, government or authority external to SND, any information that has been compiled through association with SND which has not been made public except with written authorization from the Buyer. These obligations do not lapse upon termination of the contract.
- 6) **Use of Emblem or Name:** Unless otherwise agreed in writing; the Supplier shall not advertise nor make public the fact that it is supplying goods or services to the Buyer, nor shall the Supplier in any way whatsoever use the name or emblem of SND in connection with its business or otherwise.
- 7) **Observance of Law:** The Supplier shall comply with all laws, ordinances, rules and regulations bearing upon the performance of its obligations under the terms of the contract.
- 8) **Force Majeure:** The meaning of the term can be taken to mean acts of God, war (declared or not), invasion, revolution, insurrection or acts similar in nature or force.
 - a. In the event of and as soon as possible after the occurrence of any cause deemed force majeure, the Supplier must inform the Buyer of the full particulars in writing. If the supplier is rendered unable either in part or in whole to perform its obligations then the Buyer shall take such action as it considers, in its sole discretion, to be appropriate or necessary in the circumstances.
 - b. if the Supplier is permanently rendered incapable in whole or part by reason of force majeure to complete its obligations and responsibilities under the contract then the Buyer will have the right to suspend or terminate the contract on the same terms and conditions laid out in section 9, Cancellation.
- 9) **Cancellation:** The Buyer reserves the right to cancel the contract should it suspend its activities or through changes to its mandate by virtue of the Executive Council of SND and/or lack of funding. In such a case the Supplier shall be reimbursed by SND for all reasonable costs incurred by the Supplier, including all materials satisfactory delivered and conforming to specification and terms of contract, prior to receipt of the termination notice.
 - a. Should the supplier encounter solvency problems including, but not limited to, bankruptcy, liquidation, receivership and similar, the buyer reserves the right to terminate the contract immediately without prejudice to any other right or remedy it may have under the terms of these conditions.
- 10) **Warranty:** The Supplier shall provide the Buyer with all manufacturers' warranties. The supplier warrants that all goods supplied in relation to the contract meets specification, is defect free and is fit for the purpose of the intended use. If, during the warranty period, the goods are found to be defective or non- conforming to specification, the Supplier shall promptly rectify the defect. If the defect is permanent then at the choice of the Buyer the Supplier will either replace the item at their cost or reimburse the Buyer.

- 11) **Inspection and Test:** The Supplier must inspect the goods prior to dispatch to ensure conformance to specification and/or any other provisions of the contract. The Buyer reserves the right to inspect the goods for compliance with specifications and provisions of the contract. If, in the Buyers’ opinion, the goods and/or services do not comply with the specification, the Buyer will Inform the Supplier in writing. In such a case the Supplier shall take the necessary action to ensure compliance, liability for any additional cost incurred for rectifying compliance will rest with the Supplier.
- 12) **Changes:** The Buyer reserves the right to make reasonable changes at any time to the specification, drawings, plans, quantity, packing instructions, destination, or delivery instruction. If any such change affects the price of goods or performance of service the Supplier and Buyer may negotiate an equitable adjustment to the contract, provided that the Supplier claims for adjustments in writing to the Buyer within 30 days from being notified of any change.
- 13) **Export License:** If export licenses are required for the goods, the Supplier is responsible for obtaining that license.
- 14) **Payment Terms:** Unless otherwise agreed, payment terms will be net 30 days from receipt of a correctly prepared invoice.

ESSENTIAL REQUIRED DOCUMENTS

The tenderer must attach the following documents to the tender to be submitted:

- i). Business registration certificate or Certificate of incorporation
- ii). CR12
- iii). Valid Business permit
- iv). PIN no & KRA Compliance certificate v). Duly filled, completed and stamped BOQ
- v). vi). Proof of similar assignments completed
- vii) Audited Report for the last 2 years or Bank Statement for the last 6 month

For Official Use Only

No.	Name of staff	Designation	Date	Signature
1				
2				
3				

4				
5				

NB Quotation to be filled as per the specification given and to be submitted on or before **8th April 2024** via procurement@sndafrica.org or to be delivered to **SND** offices at **Isiolo, Marsabit or Moyale**

NB 2 : The RFQ should be referenced **SND -PIK/ 10 /2025- 001** as the subject **of the Email or on the ENVELOPE**

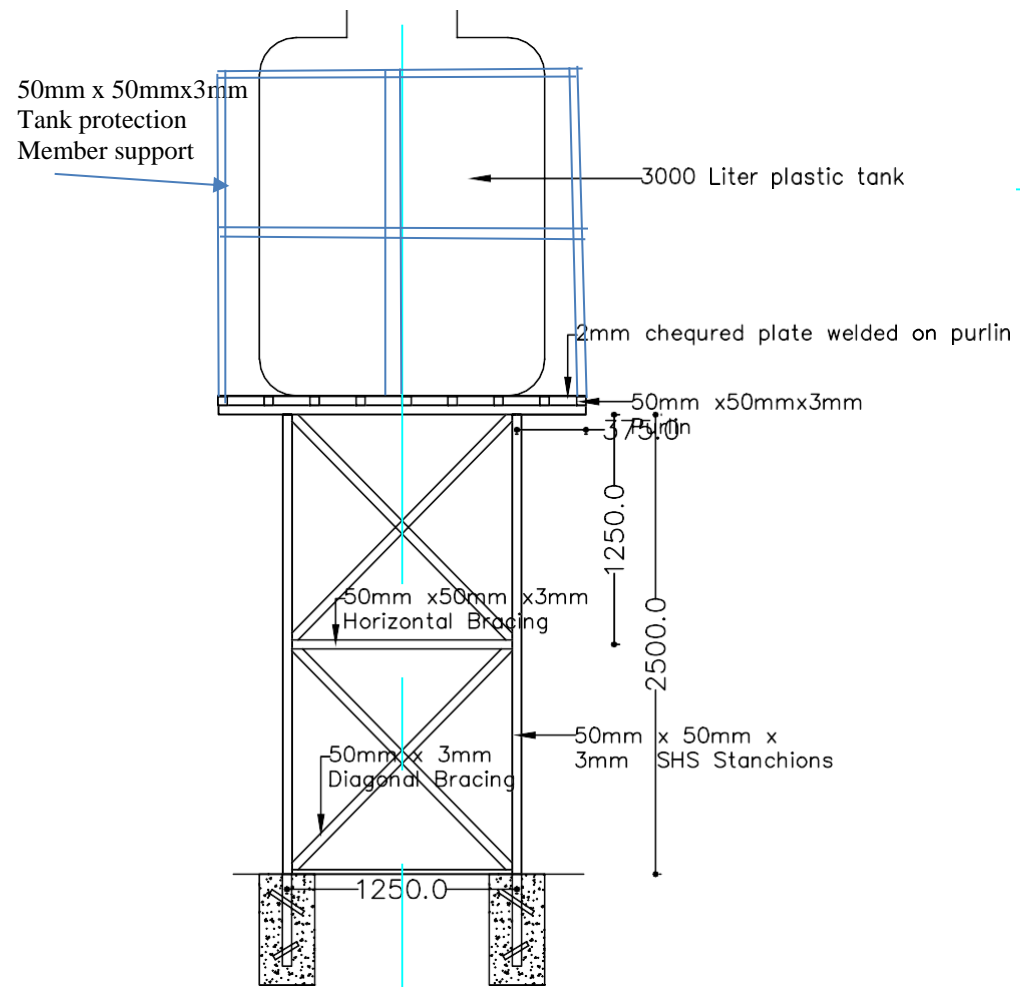
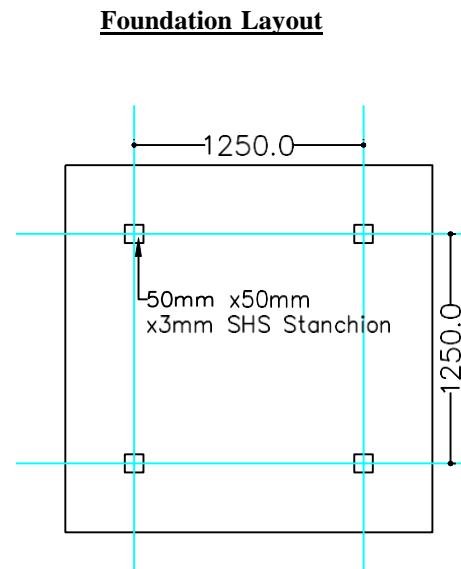
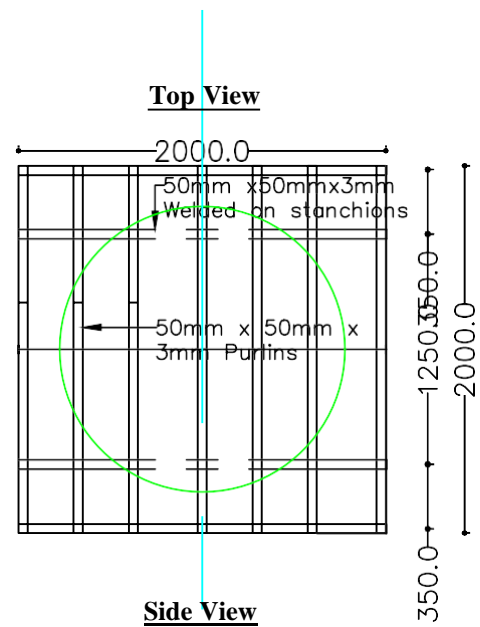

Notes:

- All Dimensions to be confirmed on site prior to commencement of works, any discrepancies should be reported for clarifications
- All Dimensions are in mm unless stated otherwise
- Depth of foundation to be determined on site
- All foundations should be excavated to firm grounds
- All foundations to be cast using concrete C20 ratio 1:2:4

Revision

No.	Date	Description

Consultant

Designed & Drawn by	Checked & Approved by
SND	

Project Title

2.5 mtrs Elevated tank structure

Date	Drawing No.
March 2025	

Scale	Sheet No.	Paper Size

Notes:

- All Dimensions to be confirmed on site prior to commencement of works, any discrepancies should be reported for clarifications
- All Dimensions are in mm unless stated otherwise
- Depth of foundation to be determined on site
- All foundations should be excavated to firm grounds
- All foundations to be cast using concrete C20 ratio 1:2:4

Revision

No.	Date	Description

Consultant

Designed & Drawn by	Checked & Approved by
SND	

Project Title

12mtrs x 12mtrs shadenet structure details

Date	Drawing No.
March 2025	

Scale	Sheet No.	Paper Size

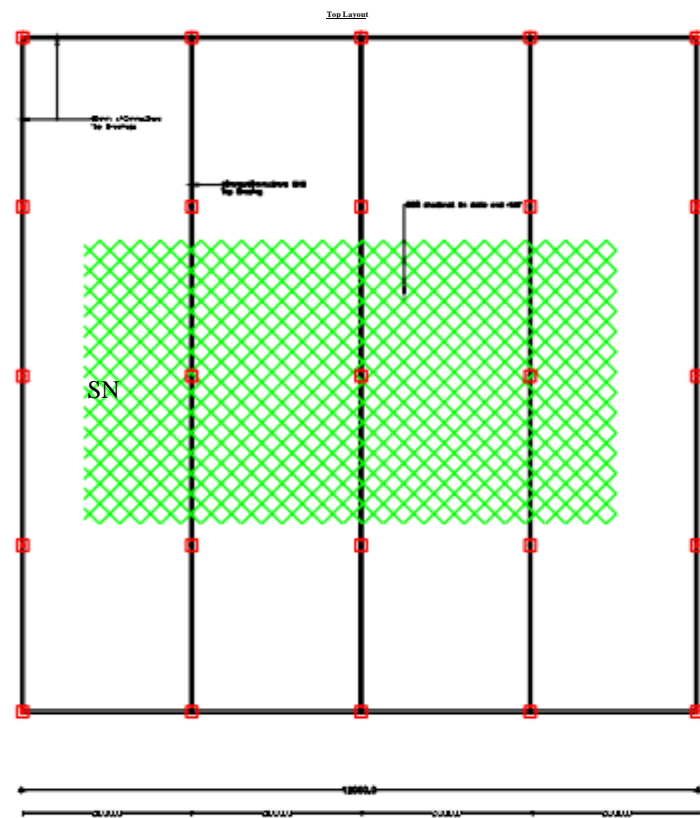
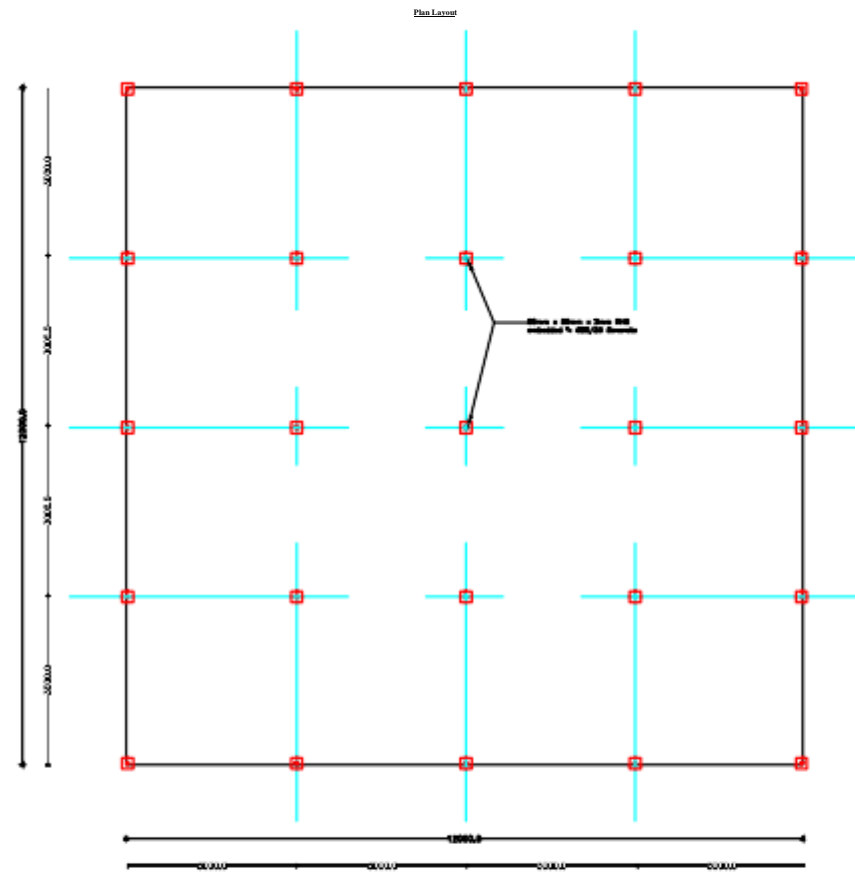

Side View

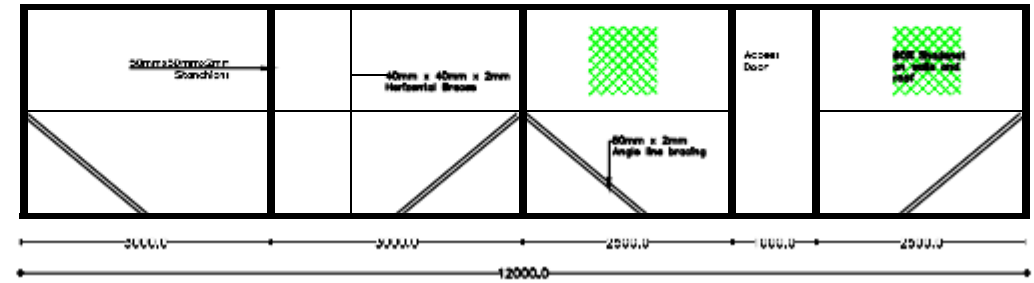

Sections

